

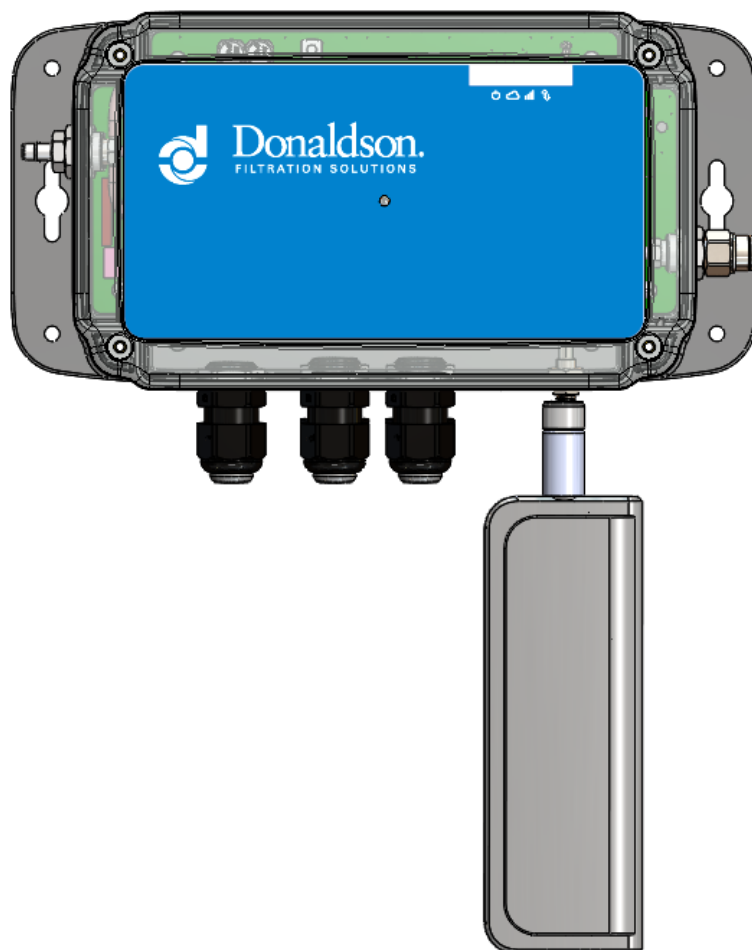

# Donaldson™ iCue™ Sensor Integrated Gateway

## Installation, Operation and Maintenance Manual



This manual contains specific precautions related to worker safety. The hazard alert image denotes safety related instructions and warnings in this manual. **DO NOT** install, operate, or perform maintenance on this product until you have read and understood the instructions, precautions and warnings contained within this manual.

## IMPORTANT NOTES

This manual has been supplied to assist with the installation, operation and maintenance of the Donaldson™ iCue™ Sensor Integrated Gateway. Please read the manual before installing, operating, or performing maintenance on this device as it contains specific precautions for worker safety. It is the owner's responsibility to ensure that this manual is available for use by installers, operators and maintenance personnel that will be working with this dust collector accessory. This manual is the property of the owner. **DO NOT** operate the device until you have read and understood the instructions and warnings located in the installation and operation manual.

For additional copies of this manual, contact [iCueSupport@donaldson.com](mailto:iCueSupport@donaldson.com).



The Safety Alert Symbol indicates a hazardous situation which, if not avoided could result in death or serious injury. Obey all safety messages following this symbol to avoid possible injury or death. The possible hazards are explained in the associated text messages.

### **NOTICE**

**NOTICE** indicates a potential situation or practice which is not expected to result in personal injury, but which if not avoided, may result in damage to equipment.

## Disclaimers

Information in this document is subject to change without notice and does not represent a commitment on the part of the Donaldson Company, Inc. Donaldson provides this documents "as is," without warranty of any kind, expressed or implied, including, but not limited to, the implied warranties of fitness or merchantability for a particular purpose. Donaldson may make improvements and/or changes in this manual or in the product(s) and/or the programs described in this manual at any time.

## Contents

IMPORTANT NOTES .....	i
1 Safety Communication .....	1
2 Product Description .....	2
System Description .....	2
Technical Specifications .....	2
3 Operation .....	3
4 Installation .....	3
Location Considerations .....	3
Overview .....	3
Mounting .....	4
Gateway Electrical Installation .....	4
Low Pressure ( $\Delta P$ ) Pneumatic Installation .....	5
High Pressure (Compressed Air) Pneumatic Installation .....	5
Gateway Final Assembly .....	6
5 Replacement Parts List .....	6
6 Terminal Strip Designators .....	7
7 Troubleshooting .....	8
8 Optional Sensor Wiring .....	10
Analog Sensors .....	10
Digital Sensors .....	12
Appendix A - Regulatory Information .....	A1
Service Notes .....	A3

## 1 Safety Communication



The Donaldson™ iCue™ Sensor Integrated Gateway should not be used to detect, monitor, warn, or alert personnel to hazards, potential safety issues, or combustion risks. Users should not rely on readings from the product to provide emergency or hazard prevention or for emergency response activities and decisions. Users remain solely responsible for maintaining a safe work environment. All dust collection equipment and accessories should be operated and maintained in accordance with the manufacturer's instructions.

Many factors beyond the control of Donaldson can affect the use and performance of Donaldson products in a particular application, including the conditions under which the product is used.

Since these factors are uniquely within the user's knowledge and control, it is essential the user evaluate the Donaldson products to determine whether the product is fit for the particular purpose and suitable for the user's application.

The device is not designed or approved to be used in any Hazardous Locations. Do not install or operate device in an area classified as hazardous.

Electrical installation must be performed by a qualified electrician.

Only qualified maintenance personnel should service this equipment.

Prior to installing or maintaining equipment, ensure all energy sources are put into a safe condition by following your facilities approved energy-control procedures.

This system does not replace the need for any routine or required monitoring or maintenance of your dust collection system. Donaldson does not guarantee the accuracy of any transmitted values.

## 2 Product Description

### System Description

The Donaldson™ iCue™ Sensor Integrated Gateway is designed for use with Donaldson's iCue™ Connected Filtration Service for Dust Collectors.

The gateway captures data from sensors and transmits that data wirelessly to the web-based Donaldson iCue application. The gateway is independent of the dust collector control system.

Sensors:

The gateway has internal sensors for sensing filter differential pressure and compressed air pressure of the dust collector. The gateway also has inputs for Donaldson approved optional sensors, which are wired into the gateway.

Communications:

The gateway utilizes a cellular connection to transmit sensor data to the Donaldson iCue application. The cellular data plan and preinstalled SIM card are provided by Donaldson. The SIM card will only work with Donaldson's service and should not be removed.

Note: This manual only covers the installation, operation and troubleshooting of the Donaldson™ iCue™ Sensor Integrated Gateway. Reference the documentation section in the dashboard application for additional information on configuring and using the application.

### Technical Specifications

Specifications	
<b>General</b>	
Input Power	Gateway: 7-32VDC; 10W max Supplied Class 2 AC/DC Converter: 90-305VAC, 47-63Hz, 40W max
Cellular Technologies	LTE
Dimensions	7.63 x 4.63 x 3.09 in. (193.80 x 117.60 x 78.49 mm)
Weight	1.5-lbs
Operating Temperature	-40 to 85C (-40 to 185F)
Ingress Rating	IP66
<b>Sensor Ratings</b>	
Vacuum	27 inches of H2O (6.72 Kpa)
Compressed Air Pressure	150 psi (10.34 bar)
Temperature Range	-40 to 85C (-40 to 185F)
External Inputs	Analog: 4 Inputs; 4-20mA or 0-10V. 24VDC Supply (100 mA max) Digital: 2 Inputs; Dry contact closure
<b>Certifications</b>	
Certifications	FCC, IC

### 3 Operation

The gateway is always on, monitoring the sensors associated with the solution. If a sensor value exceeds the user-defined alert thresholds, the gateway will communicate that data to the Donaldson iCue application for alerting purposes. Otherwise, during normal operation the gateway communicates to the Donaldson iCue application at predefined intervals.

LEDs on the gateway indicate the status of the gateway. Reference the Troubleshooting section for definition of the LED states.

### 4 Installation



Electrical installation must be performed by a qualified electrician and comply with all applicable national and local codes.

Compressed air installation must be performed by a qualified pipe fitter.

#### **NOTICE**

Penetrations into the dust collector must be air and dust tight.

#### **Location Considerations**

The gateway should be installed in a convenient location that does not interfere with any safety systems or the normal operation and maintenance of the collector. The preferred location is as high as feasible to increase the cellular signal strength.

#### **Overview**

The hardware kit received includes the gateway and other accessories required for installation; reference Replacement Parts List for what is included in the kit. There may be situations where additional materials are needed to complete the installation. A typical installation will involve the following steps:

1. Shut down the dust collector and isolate the compressed air supply source.
2. Install the Donaldson gateway.
3. Connect pneumatic tubing to the gateway.
4. Connect optional sensors to the gateway.
5. Attach the antenna to the gateway.

## Mounting

### Magnets

Magnets with pre-applied adhesive have been supplied to allow for quick and easy installation. The magnets can be applied to the gateway and/or the power supply. To use the magnetic mounts:

1. Verify the device surface is clean and dry.
2. Remove the film from the adhesive disc mounted to the magnet and firmly press the magnet into place.
3. Remove the metallic keeper and insulator from the magnets and mount the device.

Note: Allow 20 minutes for the adhesive to cure prior to mounting the gateway from a metallic surface.

### Flange

The gateway and power supply may be mounted using the mounting flanges of each device. Hardware to mount the components using the flanges is to be provided by the installer.

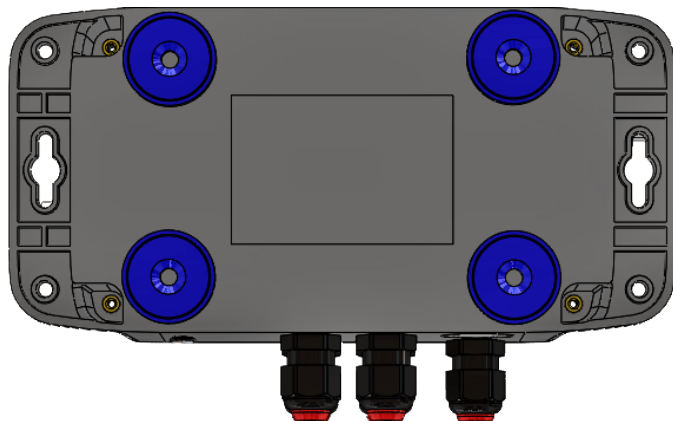

## Gateway Electrical Installation

The Gateway requires 7-32 VDC input power. A single-phase power supply is included in the kit to power the gateway. Reference Terminal Strip Designators for terminal strip locations when installing the VDC power wiring. Reference the power supply label for wire color coding.

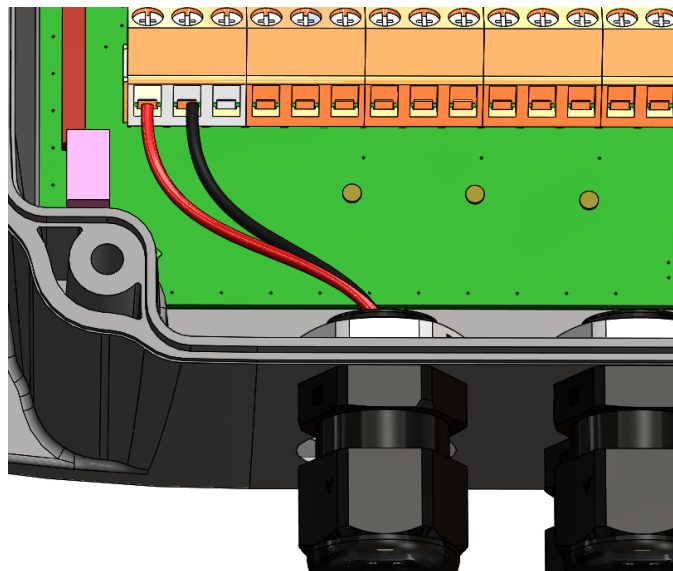

## Low Pressure ( $\Delta P$ ) Pneumatic Installation

Note: This kit contains barbed t-fittings for use with 3/16-in ID flexible tubing. Depending on the configuration of the dust collector, additional material may be required.

1. Insert a t-fitting into each filter pressure sensing line (clean air and dirty air). Reference the dust collector manual for assistance in identifying the filter pressure sense lines.

Notice: To prevent gateway damage from condensation, it is recommended that the gateway is installed above the location of the filter pressure sense line ports.

2. Using the supplied 3/16-in ID translucent blue tubing, connect the 'dirty air' pressure sense line to the Dirty port of the gateway.
3. Using the supplied 3/16-in ID translucent blue tubing, connect the 'clean air' pressure sense line to the Clean port of the gateway.

Notice: To prevent inaccurate sensor readings, it is recommended the tubing is installed in such a manner to avoid low spots where condensation may accumulate.

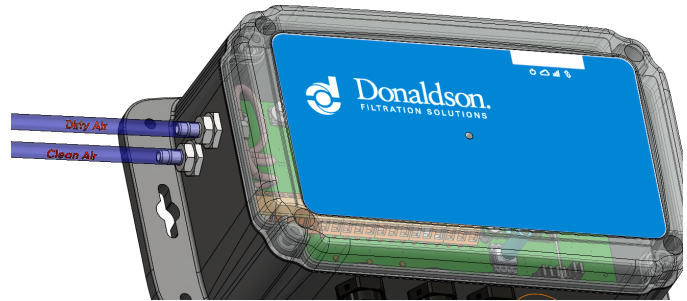

## High Pressure (Compressed Air) Pneumatic Installation

Note: Depending on the configuration of the dust collector, additional pipe fittings may be required.

1. Isolate, lockout, and depressurize the compressed air manifold.
2. Install the 1/4 NPT push-to-connect fitting into an unused port on the compressed air manifold. If no ports are available, the fitting can be installed in a tee for the incoming air to the manifold.
3. Install the 1/4" OD solid blue tubing between the fitting on the compressed air manifold and the gateway.
4. Restore the compressed air supply to the manifold.

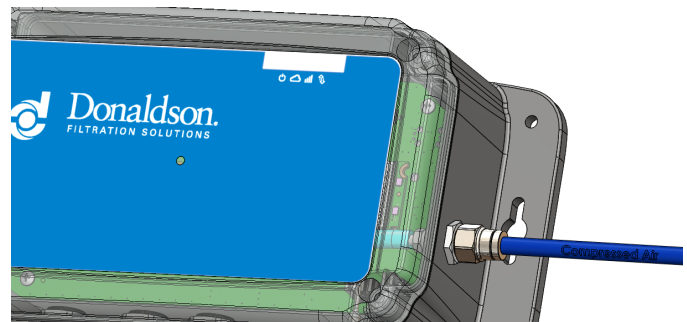



## Gateway Final Assembly

1. Connect the cellular antenna and hand tighten.
2. Restore power to the gateway.
3. Once the gateway is energized and through its startup routine (all LEDs Red, Orange, Green). Verify the Power and iCue Service Connectivity LEDs turn green. This may take several minutes.

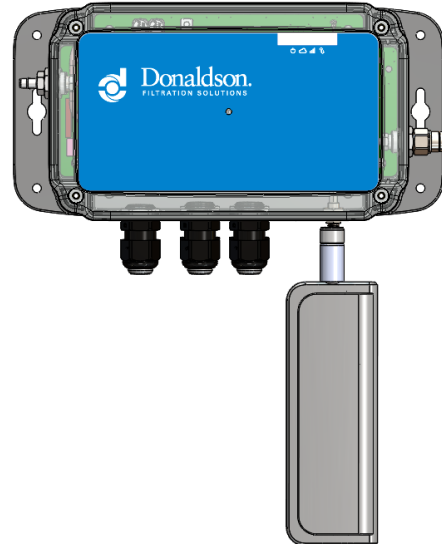

## 5 Replacement Parts List

Part Number	Description
R060015	Kit, Sensor Gateway, North America (includes antenna, power supply, Sensor Gateway Assembly, magnet, tubing and fittings)
R060028	Sensor Gateway Assembly
R060020	Antenna, RF, 4G LTE
R060021	Power Supply, 24VDC, 40W

## 6 Terminal Strip Designators

The following table denotes the use of each terminal on the internal gateway terminal strip as well as any limitations.

Terminal Number	Terminal Name	Input Constraints
1	DC Power +	7-32 VDC
2	DC Power -	6 EA
3	Chassis Ground	1 EA
4	Analog Input 1 - 24VDC Output	Max output 25 mA
5	Analog Input 1 - Input Signal	10VDC, 20mA max
6	Analog Input 1 - Ground	1 EA
7	Analog Input 2 - 24VDC Output	2 EA
8	Analog Input 2 - Input Signal	10VDC, 20mA, max
9	Analog Input 2 - Ground	
10	Analog Input 3 - 24VDC Output	Max output 25 mA
11	Analog Input 3 - Input Signal	10VDC, 20mA max
12	Analog Input 3 - Ground	
13	Analog Input 4 - 24VDC Output	Max output 25 mA
14	Analog Input 4 - Input Signal	10VDC, 20mA max
15	Analog Input 4 - Ground	
16	Digital Input 1 - 3.3VDC Output	Dry Contact Supply - not for device power
17	Digital Input 1 - Input Signal	3.3VDC Max
18	Digital Input 1 - Ground	
19	Digital Input 2 - 3.3VDC Output	Dry Contact Supply - not for device power
20	Digital Input 2 - Input Signal	3.3VDC Max
21	Digital Input 2 - Ground	

## 7 Troubleshooting

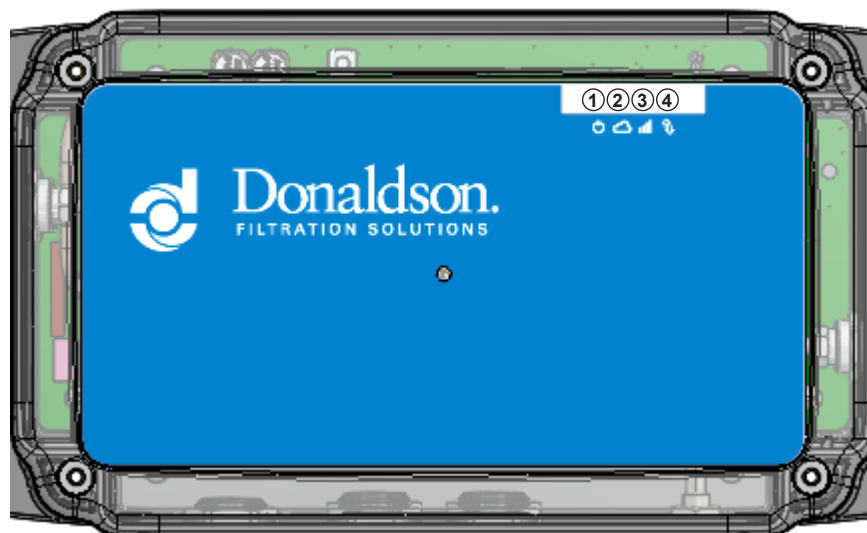

Item	LED	Color	Input
1	Power	Green	Power On
		Orange	Data transmission trigger by wake-up switch
2	iCue Service Connectivity	Green	Connected to Donaldson iCue application
		Orange	Initializing connection to Donaldson iCue application
		Red	Connection failure
		Off	Not connected to Donaldson iCue application
3	Cellular Strength	Green	Good connection quality
		Orange	Medium connection quality
		Red	Low connection quality
		Off	No cellular connection
4	Data Transmission	Green	On while sending messages to Donaldson iCue application

Problem	Remedy
<b>Cellular Strength LED is OFF or Red</b>	<p>Verify the cellular antenna is securely installed on the device and not damaged.</p> <p>Move the device to a higher location.</p> <p>Install a cabled antenna and move it to another location where the network signal can be properly received. A magnetic cable mount can be purchased when needed by contacting <a href="mailto:iCueSupport@Donaldson.com">iCueSupport@Donaldson.com</a>.</p>
<b>iCue Service Connectivity LED is not Green</b>	<p>If Cellular Strength LED is OFF or Red, reference troubleshooting for that condition.</p> <p>Note: it may take up to 5 minutes for the iCue Service Connectivity LED to turn green after the Cellular LED illuminates.</p> <p>Contact <a href="mailto:iCueSupport@Donaldson.com">iCueSupport@Donaldson.com</a>.</p>
<b>LEDs Blinking</b>	<p>The LEDs blink during unit start-up, infrequent normal processes and as a result of abnormal behavior. If you notice the LEDs blinking, monitor the unit for five minutes. If the LEDs continue to blink after this period of time, contact iCue Support at <a href="mailto:iCueSupport@Donaldson.com">iCueSupport@Donaldson.com</a>.</p>

**If additional troubleshooting assistance is required, please contact [iCueSupport@Donaldson.com](mailto:iCueSupport@Donaldson.com).**

## 8 Optional Sensor Wiring

Only Donaldson approved optional sensors should be used with the Donaldson™ iCue™ Sensor Integrated Gateway. The gateway can accommodate up to four (4) analog sensors and two (2) digital inputs.

### Analog Sensors

The Donaldson™ iCue™ Sensor Integrated Gateway can accommodate analog sensors with a 0-10VDC or 0/4-20mA output. A physical jumper on the gateway circuit board is used to select the sensor input type.

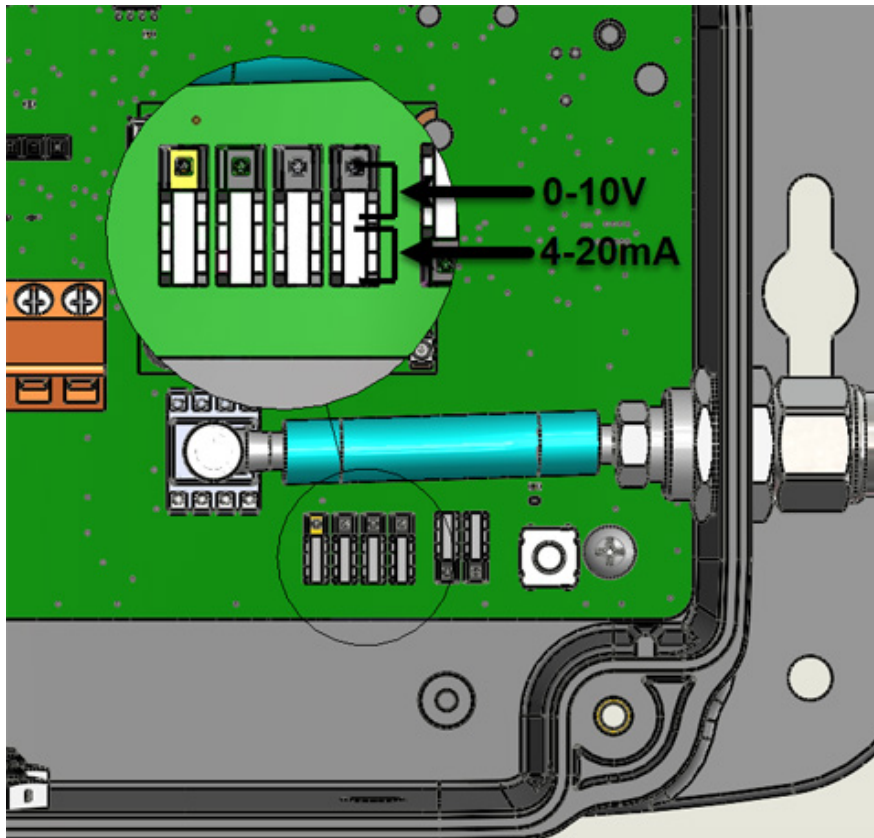

The Donaldson™ iCue™ Sensor Integrated Gateway can support 2, 3, or 4 wire sensors using the following wiring configurations. These diagrams are representative of installing an analog sensor on any of the four analog input lines.

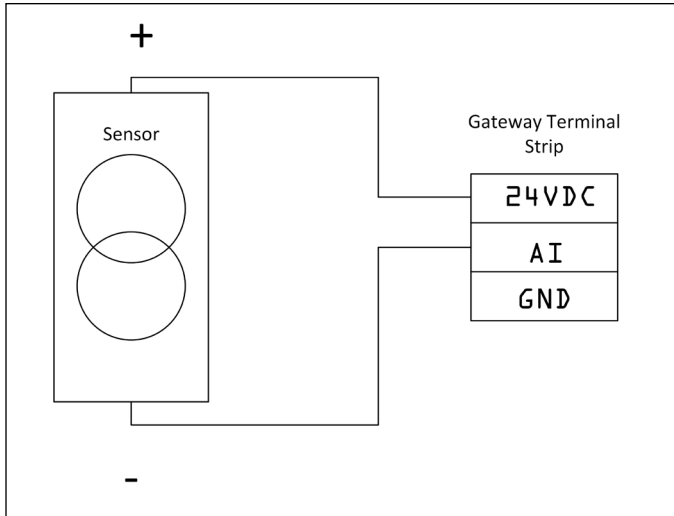

2 Wire Sensor

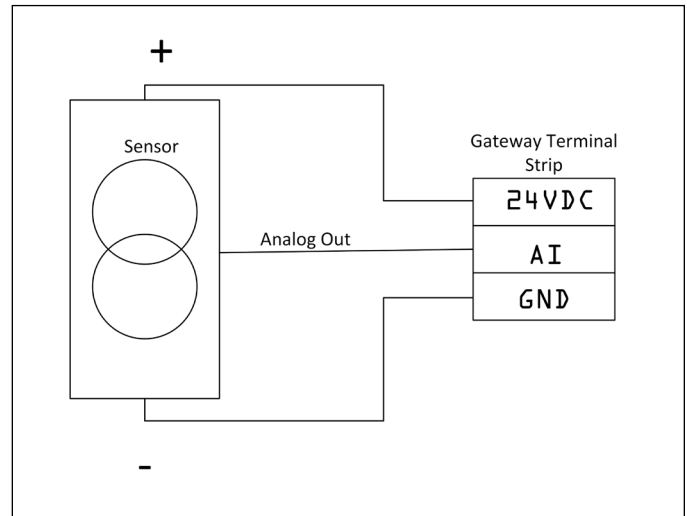

3 Wire Sensor

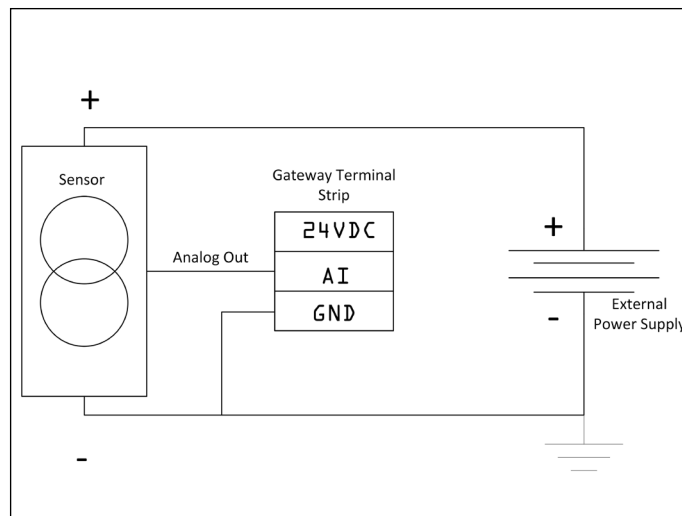

4 Wire Sensor

### Digital Sensors

The Donaldson™ iCue™ Sensor Integrated Gateway can accommodate sensors with normally open or normally closed dry contacts. A physical jumper on the gateway circuit board is used to configure the board for the appropriate sensing scenario and should be set according to the following position:

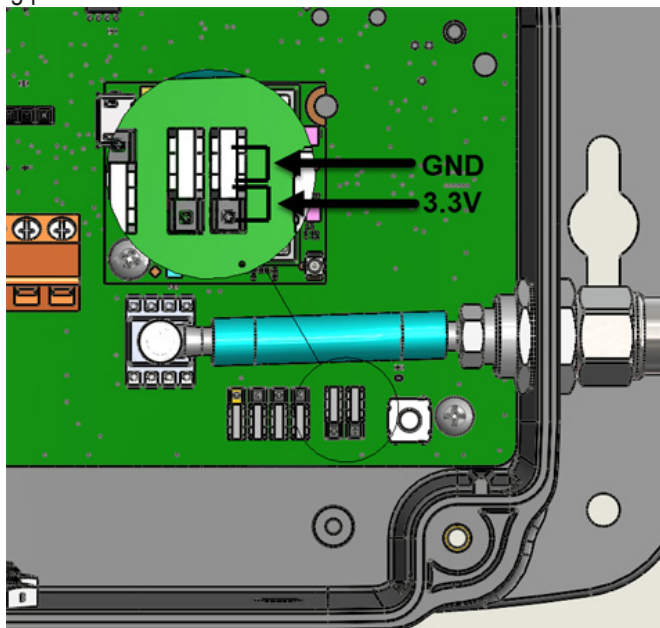

	Wiring Diagram	Sensed Stated - By Gateway		Jumper Setting
		Unactuated Switch State	Actuated Switch State	
Normally Open Contact - High	Digital High Switch	Low	High	GND
Normally Closed Contact - High	Digital High Switch	High	Low	GND
Normally Open Contact - Low	Digital Low Switch	High	Low	3V3
Normally Closed Contact - Low	Digital Low Switch	Low	High	3V3

Note: This is a low voltage connection. 3.3VDC may be present on one side of the contact.

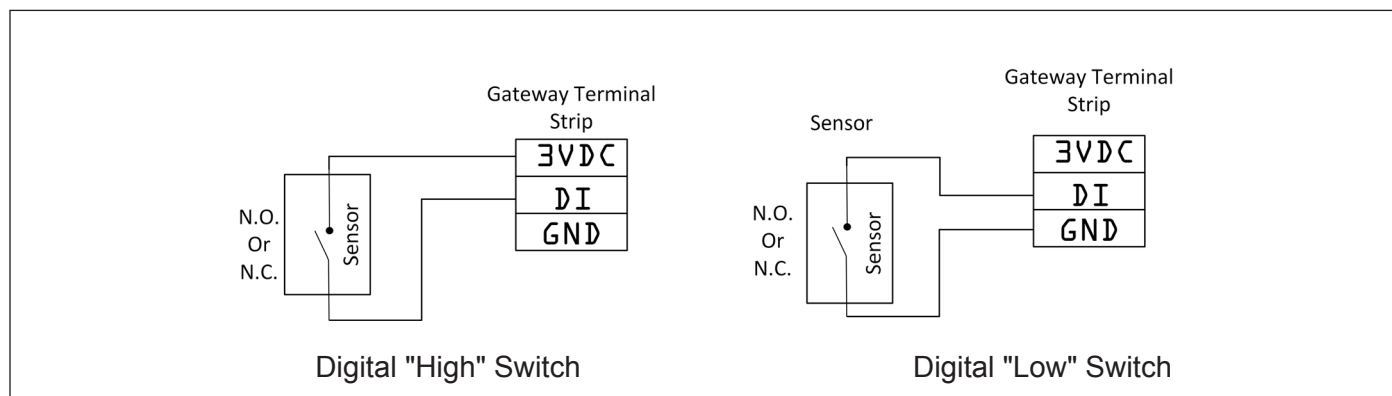

## Appendix A - Regulatory Information

### United States



#### Class B:

NOTE: This equipment has been tested and found to comply with the limits for a Class B digital device, pursuant to part 15 of the FCC Rules. These limits are designed to provide reasonable protection against harmful interference in a commercial or residential installation. This equipment generates, uses and can radiate radio frequency energy and, if not installed and used in accordance with the instructions, may cause harmful interference to radio communications. However, there is no guarantee that interference will not occur in a particular installation. If this equipment does cause harmful interference to radio or television reception, which can be determined by turning the equipment off and on, the user is encouraged to try to correct the interference by one or more of the following measures:

- Reorient or relocate the receiving antenna.
- Increase the separation between the equipment and receiver.
- Connect the equipment into an outlet on a circuit different from that to which the receiver is connected.
- Consult the dealer or an experienced radio/TV technician for help.

#### Contains FCC ID(s): XPY2AGQN4NNN

Radio frequency radiation exposure information: This equipment complies with radiation exposure limits prescribed for an uncontrolled environment for fixed and mobile use conditions. This equipment should be installed and operated with a minimum distance of 20 cm between the radiator and the body of the user or nearby persons. The system must only be used with approved antennas and accessories. Any changes or modifications made to this device that are not expressly approved by the cellular module manufacturer could void the user's authority to operate the equipment.



## Canada

### Radio Frequency (RF) Exposure Information

The radiated output power of this device is below the Innovation, Science and Economic Development Canada (ISED) radio frequency exposure limits. The device should be used in such a manner such that the potential for human contact during normal operation is minimized. This device has been evaluated and shown compliant with the ISED RF Exposure limits under mobile exposure conditions (antennas are greater than 20 cm from a person's body).

This device has been certified for use in Canada. Status of the listing in the ISED's REL (Radio Equipment List) can be found at the following web address: <http://www.ic.gc.ca/app/sitt/reitel/srch/nwRdSrch.do?lang=eng>

Additional Canadian information on RF exposure also can be found at the following web address: <http://www.ic.gc.ca/eic/site/smt-gst.nsf/eng/sf08792.html>

### Contains IC ID(s): 8595A-2AGQN4NNN

Any changes or modifications made to this device that are not expressly approved by the cellular module manufacturer could void the user's authority to operate the equipment.

### CLASS B:

Innovation, Science and Economic Development Canada (ISED) Notices  
This Class B digital apparatus complies with Canadian CAN ICES-3(B) / NMB-3(B).  
Operation is subject to the following two conditions:

- This device may not cause interference.
- This device must accept any interference, including interference that may cause undesired operation of the device.

### Informations concernant l'exposition aux frux friti radio (RF)

La puissance de sortie émise par l'appareil de sans fil cet appareil est inférieure à la limite d'exposition aux fréquences radio d'Innovation, Sciences et Développement économique Canada (ISDE). L'appareil doit être utilisé de manière à minimiser les risques de contact humain lors du fonctionnement normal. Ce pe pmal.neme a éa éa pma et dd dal. conforme aux limites d'exposition aux frux friti radio (RF) d'ISDE lorsqu'il est installl dans des produits hhouu particuliers qui fonctionnent dans des conditions d'exposition 'exposappareils mobiles (les antennes se situent ituent ent sicutimt ent du corps d'une personne). Ce p. Ce pe). C est homologuu pour l'utilisation au Canada. Pour consulter l'entrna correspondant orlorrespond dans la liste d'équipement radio (REL - Radio Equipment List) d'ISDE rendez-vous sur: <http://www.ic.gc.ca/app/sitt/reitel/srch/nwRdSrch.do?lang=fra>

Pour des informations suppllations su concernant l'exposition aux RF au Canada rendez-vous sur: <http://www.ic.gc.ca/eic/site/smt-gst.nsf/fra/sf08792.html>

### CLASS B:

Avis d'Innovation, Sciences et Développement économique Canada (ISDE)  
Cet appareil numérique de classe B est conforme aux normes canadiennes CAN ICES-3(B) / NMB-3(B).  
Son fonctionnement est soumis aux deux conditions suivantes:

- Cet appareil ne doit pas causer d'interfser d'.
- Cet appareil doit accepter toute interffnterf, notamment les interfnterfes qui peuvent affecter son fonctionnement.



**Supplier's Declaration of Conformity  
47 CFR § 2.1077 Compliance Information**

**Unique Identifier:** Donaldson™ iCue™ Sensor Integrated Gateway Part Number: R060028

**Responsible Party – U.S. Contact Information**

Donaldson Company, Inc.  
1400 W 94th Street  
Bloomington, MN  
55431

1-833-898-5996

**FCC Compliance Statement** (*e.g.*, products subject to Part 15)

This device complies with Part 15 of the FCC Rules. Operation is subject to the following two conditions: (1) This device may not cause harmful interference, and (2) this device must accept any interference received, including interference that may cause undesired operation.



**Important Notice**

Many factors beyond the control of Donaldson can affect the use and performance of Donaldson products in a particular application, including the conditions under which the product is used. Since these factors are uniquely within the user's knowledge and control, it is essential the user evaluate the products to determine whether the product is fit for the particular purpose and suitable for the user's application. All products, product specifications, availability and data are subject to change without notice, and may vary by region or country.

