

Donaldson<sup>®</sup>  
Torit<sup>®</sup>



**AIRPLUS**  
Industrial  
www.airplusindustrial.ca 604-882-8886

## LP Baghouse

72LP - 252LP (All Welded)

### Installation and Operation Manual

Installation, Operation, and Service Information



This manual contains specific precautions related to worker safety. The hazard alert image denotes safety related instructions and warnings in this manual. DO NOT install, operate, or perform maintenance on this collector until you have read and understood the instructions, precautions and warnings contained within this manual.

English  
Master Language

IOM AG8627601 (ENG)  
Revision 0

## IMPORTANT NOTES

This manual has been supplied to assist with the installation, operation and maintenance for the collector purchased. Please read the manual before installing, operating, or performing maintenance on the collector as it contains specific precautions for worker safety. It is the owner's responsibility to ensure that this manual is available for use by installers, operators and maintenance personnel that will be working with this collector. This manual is the property of the owner and should be left with the collector when installation has been completed. **DO NOT** operate this collector until you have read and understood the instructions and warnings located in the installation and operation manual. For additional copies of this manual, contact Donaldson Torit.



The Safety Alert Symbol indicates a hazardous situation which, if not avoided could result in death or serious injury. Obey all safety messages following this symbol to avoid possible injury or death. The possible hazards are explained in the associated text messages.

### **NOTICE**

**NOTICE** indicates a potential situation or practice which is not expected to result in personal injury, but which if not avoided, may result in damage to equipment.

## Contents

IMPORTANT NOTES .....	2
1 Safety Communication .....	4
2 Product Description .....	6
Rating and Specification Information .....	6
Standard Equipment .....	6
Options and Accessories .....	8
Cleaning Controls and Sensors .....	8
Magnehelic® Gauge .....	8
Hopper Discharge Accessories .....	8
Hopper Transition .....	8
Live Bottom Hopper .....	8
Rotary Airlock (RAL) .....	8
Screw Conveyor .....	8
Platform and Ladder .....	8
Explosion Relief Panels .....	8
Sprinkler Coupling .....	8
Water Overflow Valve .....	8
3 Operation .....	9
4 Product Service .....	11
Operational Checklist .....	11
Filter Replacement .....	12
Troubleshooting .....	14
Appendix A - Installation .....	16
Location and Site Selection .....	17
Delivery and Inspection .....	17
Unloading and Positioning .....	17
Lifting Information .....	18
Support Installation .....	19
Inlet Scroll Installation .....	19
Platform and Ladder Installation .....	20
Cleaning System .....	21
Filter Bag and Cage Installation .....	22
Electrical Wiring .....	22
Cleaning Controls and Sensors .....	23
Magnehelic® Gauge .....	23
Hopper Discharge Accessories .....	24
Rotary Airlock .....	24
Options and Accessories .....	25
Explosion Relief Panels .....	25
Sprinkler Coupling .....	25
Water Overflow Valve .....	25
Start-up / Commissioning Collector .....	26
Decommissioning Collector .....	27
Product Information .....	28
Service Notes .....	29
Donaldson Industrial Air Filtration Warranty .....	31

## 1 Safety Communication



Improper operation of dust collectors and/or dust control systems may contribute to conditions in a work area or facility which could result in severe personal injury, and product or property damage. All dust collection equipment should be used only for its intended purpose and should be properly selected and sized for its intended use.

Process owners have important responsibilities relating to identifying and addressing potential hazards in their processes. When the potential for handling combustible dust exists within a process the process owner should include combustion hazards in their risk management activities and should comply with applicable codes and standards related to combustible dust.

Electrical installation must be performed by a qualified electrician.

This equipment is not designed to support site ducts, piping, or electrical services. All ducts, piping, or electrical services must be adequately supported to prevent injury and/or property damage.

Site selection must account for wind, seismic zone, and other load conditions.

Equipment may reach peak sound pressure levels above 80 dB (A). Noise levels should be considered when selecting collector location.

Most dusts present safety and health hazards that require precautions. Wear eye, respiratory, head and other protection equipment suitable for the type of dust.

Some components may be heavier than they appear. Use appropriate lifting methods to avoid personal injury and/or property damage.

## Combustible Dust Hazards

Among other considerations, the current NFPA standards require owners whose processes involve potentially combustible materials to have a current Dust Hazard Analysis, which can serve as the foundation for their process hazard mitigation strategy. Mitigation may include but is not limited to:

- Prevention of all ignition sources from entering any dust collection equipment.
- Selection and implementation of fire and explosion mitigation, suppression, and isolation strategies appropriate for the risks in their process.
- Development and use of work practices to maintain safe operating conditions, and to ensure combustible dust does not accumulate within their plant or process equipment.

Donaldson designs, manufactures, and sells industrial air filtration products for a wide variety of applications. Some applications may include processes or materials with inherent fire and explosion hazards. Donaldson is neither an expert nor a certified consultant in fire, spark, or explosion detection, suppression, or control. Donaldson does not provide engineering consulting services related to process or dust hazard analyses, or code and standard compliance. Complying with applicable codes and standards and managing the risks associated with the process or materials remains the responsibility of the process owner/operator. Donaldson may provide referrals to consultants, suppliers of equipment or services related to the detection and/or mitigation of sparks, fires and/or explosions, but Donaldson does not assume responsibility for any such referrals, nor does Donaldson assume any liability for the fitness of a mitigation strategy or product for a particular installation or application. The process owner's final selection of dust collectors and risk mitigation strategies should be based on the outcome of a Dust Hazard / Process Hazard Analysis performed by the process owner. Although early engagement of a dust collector supplier provides helpful insights on the availability and features of various products, process owners should consult with a combustible dust expert and/or a process safety expert before making actual product and mitigation strategy selections.

Donaldson recommends that all industrial air filtration system designs be reviewed and approved by an expert consultant who is responsible for the integrity of the system design and compliance with applicable codes and standards. It is the process owner's responsibility to understand the risks in their process and mitigate those risks in accordance with all applicable laws, regulations and standards, including those published by the NFPA. Donaldson also recommends that proper maintenance and housekeeping procedures and work practices be evaluated, developed, and followed to maintain any industrial air filtration products in safe operating condition.

Many factors beyond the control of Donaldson can affect the use and performance of Donaldson products in a particular application, including the conditions under which the product is used. Since these factors are uniquely within the user's knowledge and control, it is essential the user evaluate the Donaldson products to determine whether the product is fit for the particular purpose and suitable for the user's application. All products, product specifications, and data (airflow, capacity, dimensions, or availability) are subject to change without notice, and may vary by region or country.

## 2 Product Description

The LP Baghouse is a continuous duty dust collector with bag-style filters designed to handle up to 141,000 cfm depending on the application and dust type. Continuous duty means the filters can be reverse air cleaned on-line without interrupting airflow through the collector. All bags are cleaned with every revolution of the cleaning arm.

The LP features a walk-in clean-air plenum, allowing filter bag service from inside the clean air plenum.

### Intended Use

The LP Baghouse collector is common in the nut, woodworking and grain industries where it effectively handles high-volume, high dust-load applications.

Sizes are available for applications with any of the following conditions or requirements:

- Heavy dust load
- No compressed air available
- A requirement for a single discharge hopper

### Rating and Specification Information

General rating and specification information can be found in the product literature provided with the collector and is available on the Donaldson website. For specific load values for a collector, see the Specification Control Drawing shipped with the collector.

### Standard Equipment

All welded collectors can be lifted from the truck to the prepared site.

### Filters

The LP collector ships with filter bags and cages. The standard bag media is Dura-Life™ which provides long life and energy savings due to lower pressure drop. Other filter bag media options are available.

### Involute Scroll Style Inlet

The inlet develops a cyclonic airflow causing heavier particulate to drop directly into the hopper. The air continues through an internal flow straightener, reduces turbulence and evenly distributes the dust-laden air within the collector cross-section and around the filter bags.

### Reverse Air Cleaning System

The cleaning system contains an internal fan with reverse air flow design. The sweep arms have a flow-stop plate which briefly keeps air from flowing through the bag filters after cleaning. This feature reduces the chances of dust from cleaned bags being re-entrained onto recently cleaned bags, resulting in lower pressure drop and reduced energy costs due to bags staying cleaner longer. The system does not require any compressed air supply.

### Hopper Access Cover

The access cover, when removed, allows access to the interior of the hopper.

### Clean Air Outlet

Clean air exists the collector through the clean air outlet located in the clean air plenum.

## Hopper Outlet

The hopper outlet is a singular outlet at the bottom of the hopper where the separated dust exits the collector and is routed to be disposed of via bin, pneumatic conveyor, screw conveyor, or other means. A rotary airlock is typically used to isolate the dust collection system from the dust disposal system.

## Collector Body

The combination of the Dirty and Clean Air plenums along with the hopper represents the total collector body.

## Leg Pack

The leg structure supports the collector body at an elevation to accommodate various dust disposal devices and systems which can be configured to meet customer needs.

## Clean Air Plenum (CAP)

Air passes through the filters and into the Clean Air Plenum(CAP) where it exists through the Clean Air Outlet.

## Tubesheet

The tubesheet is the metal panel the filters are sealed against to separate the Dirty Air and Clean Air Plenums of the collector. Through holes are cut to mount filters.

## Clean Air Plenum (CAP) Door

The Clean Air Plenum (VAP) door allows access into the Clean Air Plenum for service and inspection.

## Dirty Air Plenum (DAP)

Dust laden process air enters the Dirty Air Plenum via the involute scroll inlet. As air enters it goes through a preseparation stage and then airflow straightening before it reaches the filters. This allows the majority of the dust to drop out into the hopper and the airflow to be evened out before it gets to the filters.

## Hopper

The hopper, located at the bottom of the collector body, is the discharge point for dust that has been preseparated and pulsed off of the filters.

## Arm Drive

The arm drive consists of a gearbox, motor, tensioner, sprockets, and chain. This rotates the arm around the centerline of the collector to distribute the cleaning air.

## Sweep Arm Assembly

The sweep arm assembly is a "Tee" or "L" shaped assembly with nozzles along the bottom to distribute the cleaning air into the filter bags. The arm assembly rotates around the centerline of the collector.

## H Frame

An "H" shaped structure that supports the reverse air cleaning system.

## **Options and Accessories**

### **Cleaning Controls and Sensors**

#### **Magnehelic® Gauge**

Simple mechanical gauges that measure differential pressure. May be passive mechanical versions or digital, may include electrical contacts and user adjustable setpoints.

### **Hopper Discharge Accessories**

#### **Hopper Transition**

The collector comes with a standard size hopper outlet. Donaldson offers optional hopper outlet transitions to match up with various dust disposal devices.

#### **Live Bottom Hopper**

Short section of screw conveyor with a round to rectangle transition that handles tough dusts that bridge easily.

#### **Rotary Airlock (RAL)**

Used to isolate the dust collection system pressure from atmosphere. Options include flexible wipers, NFPA rated valves, Pneumatic conveying ready valves, and high clearance valves for tough to handle dusts.

#### **Screw Conveyor**

Can be mounted directly to the hopper outlet with the addition of an RAL at the discharge. Useful for loading bulk containers while maintaining a shorter overall height.

### **Platform and Ladder**

Collector may be equipped with a ladder and platform system for gaining access to the clean air plenum for filter bag changeout. For all ladders over 24-ft OSHA requires a ladder safety system or personal fall arrest system. As a convenience, Donaldson offers ladder safety systems as an option.

### **Explosion Relief Panels**

Collector may be equipped with optional explosion relief panels to support a process owners combustible dust mitigation strategy. Explosion vent sizing follows NFPA-68 formulas assuming outdoor location of collector with no duct or obstruction on the explosion vent panels. Contact Donaldson Torit for explosion venting requirements for other conditions.

### **Sprinkler Coupling**

Sprinkler couplings are provided for the convenience of fire control system installers. The fire control system installer shall make their own decisions on the appropriate location of fire control system components.

### **Water Overflow Valve**

An optional means to allow water evacuation. Some method of water evacuation must be provided if a water based extinguishing system is installed on the collector.



## 3 Operation



Electrical work during installation, service or maintenance must be performed by a qualified electrician and comply with all applicable national and local codes.

Turn power off and lock out all power before performing service or maintenance work.

Check that the collector is clear and free of all debris before starting.

Do not install in classified hazardous atmospheres without an enclosure rated for the application.

The LP cleaning system contains an internal fan with reverse air flow design. The sweep arms have a flow-stop plate which briefly keeps air from flowing through the bag filters after cleaning. This feature reduces the chances of dust from cleaned bags being re-entrained onto recently cleaned bags, resulting in lower pressure drop and reduced energy costs due to bags staying cleaner longer. The system does not require any compressed air supply.

During normal operation, dust-laden air enters the dirty-air inlet. The involute scroll-style inlet develops a cyclonic airflow causing heavier particulate to drop directly into the hopper. The air continues through an internal flow straightener that evenly distributes the dust-laden air within the collector cross-section and around the filter bags. After entering the collector the light dust collects on the outside surface of each filter bag forming a dust cake. Clean, filtered air passes through the filter bags to the clean-air plenum and discharges through the clean-air outlet.

## Typical Collector Operation

### Typical Start-Up Sequence

1. Start rotary airlock (if applicable).
2. Start gear box motor for cleaning arm rotation.
3. Start reverse-air cleaning assembly fan.
4. Start main system fan.
5. Start process equipment.

### Typical Shut-Down Sequence

1. Stop process equipment. Allow LP to continue operating for 3-5 minutes. Fan remains running to clear dust from conveying ducts and areas around hoods.
2. Stop main system fan. Allow LP reverse-air fan and gear box motor to continue running for 15-10 minutes. Cleaning remains active after main system fan shuts off to allow for a brief period of enhanced filter bag cleaning.
3. Stop LP reverse-air fan and gear box motor. Allow airlock to run for at least 5 minutes after reverse-air fan and gear box motor shut off to ensure dust is fully evacuated from the hopper of the LP.
4. Stop airlock.

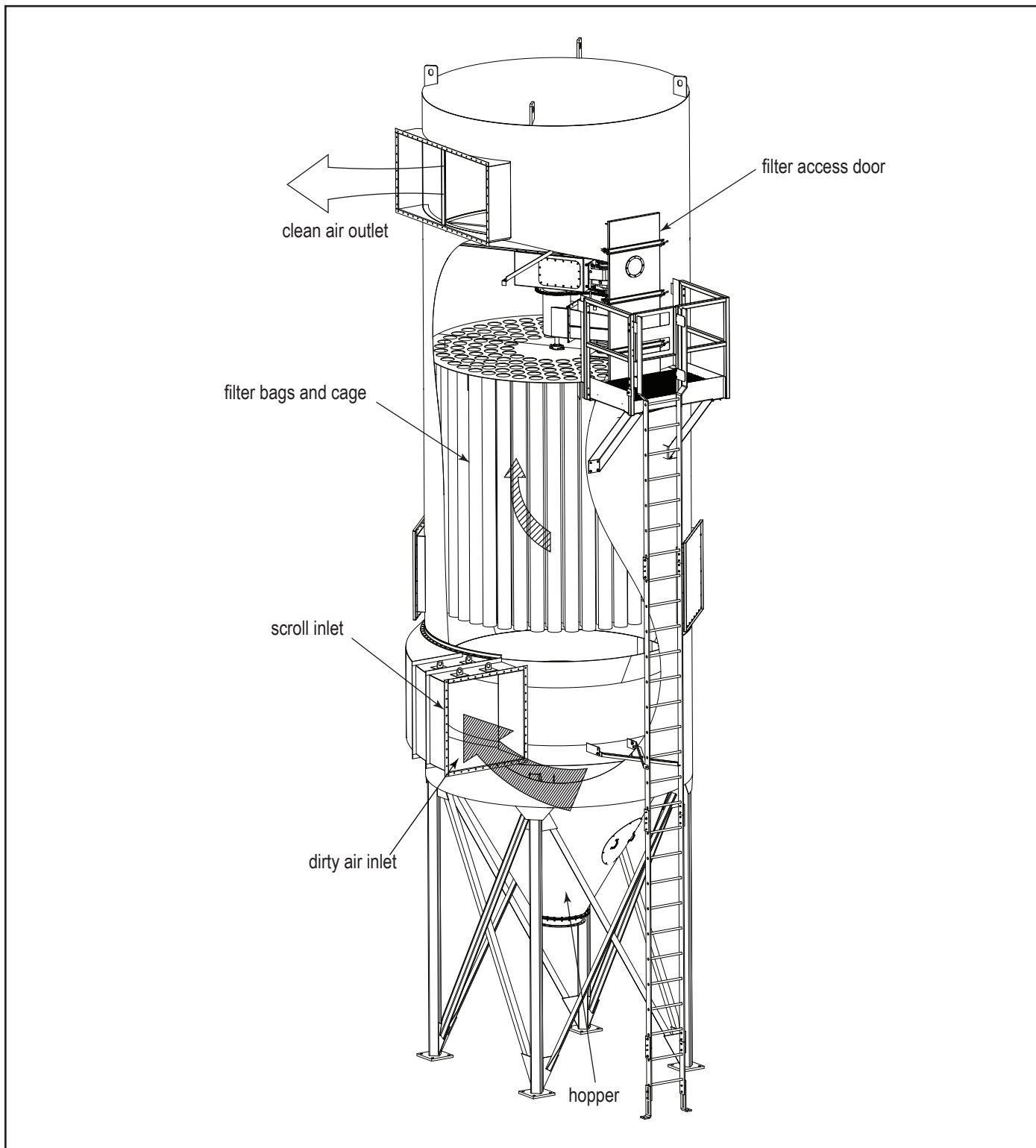

Collector Operation

## 4 Product Service



During service activities there is some potential for exposure to the dust in the collector. Most dusts present safety and health hazards that require precautions. Wear eye, respiratory, head and other protection equipment suitable for the type of dust when performing any service activities.

Use appropriate access equipment and procedures. Note the standard collector is not equipped with access platforms unless noted on the specification drawings.

LOCK-OUT all energy sources prior to performing any service or maintenance on the equipment.

Electrical service or maintenance work must be performed by a qualified electrician and comply with all applicable national and local codes.

### Operational Checklist

1. Monitor the physical condition of the collector and repair or replace any damaged components.  
Routine inspections will minimize downtime and maintain optimum system performance. This is particularly important on continuous-duty applications.
2. Monitor pressure drop across filters.
3. Abnormal changes in pressure drop may indicate a change in operating conditions and possibly a fault to be corrected.

Check the following items at the recommended intervals shown below.

DAILY-WEEKLY	
Item	Typical Condition
Pressure Drop	Between 1-in and 6-in

MONTHLY - QUARTERLY	
Item	Typical Condition
CAP Condition	Interior is clean and all filters seated
Involute inlet	No significant wear spots
Access door seals	Door seals intact, remains pliable, with no indication of air bypass
Cleaning arm drive	Operates smoothly with no noise
Monitor thickness of wear material on the cleaning sled	Look for filter cages not fully inserted into tube sheet
Cleaning arm drive chain	Clean and properly tensioned
Arm gearbox oil	Gearbox oil level is at the proper level and not excessively dirty
Explosion vents	Vents are free of obstructions and are mechanically sound and sealed with no evidence of air, water, or dust leakage.
Rotary Airlock (RAL) or discharge device	No air bypass during operation and no unusual noises
Motor rotation direction	Matches indicating arrows
If any items are not matching typical condition refer to the troubleshooting and service section. This list is not an all inclusive preventative maintenance schedule and site specific equipment, regulations and conditions. This list is only meant to be an end user reference to develop a site specific preventative maintenance schedule.	

## Filter Replacement



Most dusts present safety and health hazards that require precautions. Wear eye, respiratory, head and other protection equipment suitable for the type of dust.

Use proper safety and protective equipment when removing contaminants and filters.

Dirty filters may be heavier than they appear. Use appropriate lifting methods to avoid personal injury and/ or property damage.

Turn power OFF and lock out all power before performing service or maintenance work.

Do not operate with missing or damaged filters

## Filter Bag and Cage

1. Turn power to the collector OFF.
2. Open access door into the clean air plenum.
3. Remove cages leaving the bags hanging in dirty air plenum.
4. Push one side of snap band to deform and release from the tube sheet.
5. Push the bag down into the bottom of the dirty air plenum.
6. Repeat steps 4-5 for all filter bags and cages.  
Note: The cleaning arm will need to be manually rotated to access some bags.
7. Remove all dirty filter bags through hopper access door and dispose of in accordance with local requirements for the materials being collected.
8. From the clean-air plenum, carefully insert the snap-in filter bag through the tube sheet with the closed end oriented downward.
9. Snap the bag in place with the tube sheet between the upper and lower rings on the filter bag collar.
10. Slide the filter cage into the filter bag and seat firmly.
11. Repeat steps 8-10 for all remaining filter bags.  
Note: The cleaning arm will need to be manually rotated to access some bags.
12. Once all bags are installed, ensure the cleaning arms rotate smoothly.
13. Close the access door.

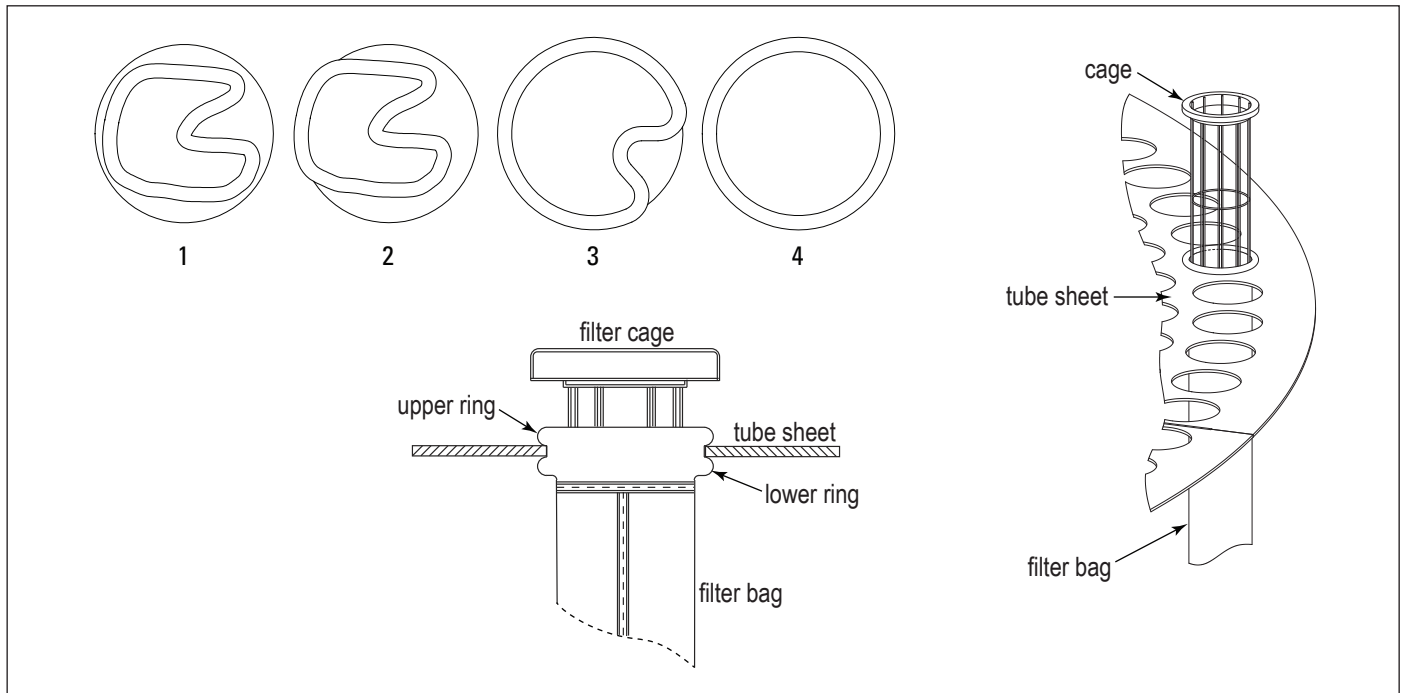

Felt Snap-In Filter Installation

## Troubleshooting

Problem	Probable Cause	Remedy
<b>Fan blower and motor do not start</b>	Improper motor wire size	Rewire using the correct wire gauge as specified by national and local codes.
	Not wired correctly	Check and correct motor wiring for supply voltage. See motor manufacturer's wiring diagram. Follow wiring diagram and the National Electric Code.
	Collector not wired for available voltage	Correct wiring for proper supply voltage.
	Input circuit down	Check power supply to motor circuit on all leads.
	Electrical supply circuit down	Check power supply circuit for proper voltage. Check for fuse or circuit breaker fault. Replace as necessary.
	Damaged motor	Replace damaged motor.
<b>Fan blower and motor start, but do not stay running</b>	Incorrect motor starter installed	Check for proper motor starter and replace if necessary.
	Access doors are open or not closed tight	Close and tighten access doors. See Filter Replacement.
	Hopper discharge open	Check that dust container is installed and properly sealed.
	Damper control not adjusted properly	Check airflow in duct. Adjust damper control until proper airflow is achieved and the blower motor's amp draw is within the manufacturer's rated amps.
	Electrical circuit overload	Check that the power supply circuit has sufficient power to run all equipment.
<b>Clean-air outlet discharging dust</b>	Filters not installed correctly	See Filter Installation.
	Filter(s) damaged or worn	Replace filters as necessary. Use only genuine Donaldson replacement parts. See Filter Replacement.
<b>Insufficient airflow</b>	Fan rotation backwards	Proper fan rotation is clockwise when viewed from the motor side or counterclockwise when viewed through the inlet cone. See Preliminary Start-Up Check.
	Access doors open or not closed tight	Check that all access doors are in place and secured. Check that the hopper discharge opening is sealed and that dust container is installed correctly.
	Fan exhaust area restricted	Check fan exhaust area for obstructions. Remove material or debris. Adjust damper flow control.
	Filters need replacement	Remove and replace using genuine Donaldson replacement filters. See Filter Replacement.
	Dust storage area overfilled or plugged	Clean out dust storage area. See Dust Disposal.
	Cleaning arm failure	Check for adequate clearance between nozzles and tubesheet for free rotation. Check drive chain for proper tension.

Problem	Probable Cause	Remedy
<b>Pressure drop not in normal operational range</b>	Collector overloaded at dust source	Check for excessive or unusual dust loading at the dust source.
	Hopper bridging	Check for proper flow at product discharge flange on filter hopper.
	Cleaning system	Check operation of LP fan.  Check operation of LP gear box and drive.  Verify no debris or condensation in tube length running to gauge
<b>Power circuit for sweep arm motor trips</b>	Interference between sweep arms and cages	Ensure all filter cages are fully seated.
		Ensure skid material is in good condition and arms rotate freely. Replace if necessary.

# **Appendix A - Installation**



## Installation



Electrical Installation (including bonding and grounding of the collector) must be performed by a qualified electrician.

This equipment is not designed to support site ducts, piping, or electrical conduit. All ducts, piping, or electrical conduit must be adequately supported to prevent injury and/or property damage.

Do not install in classified hazardous atmospheres without an enclosure rated for the application.

Service must be performed by trained and qualified maintenance personnel.

This equipment may start or stop unexpectedly from a remote location

Equipment may reach peak sound pressure levels above 80 dB (A). Noise levels should be considered when selecting equipment location.

## Location and Site Selection



Codes may regulate recirculating filtered air in your facility. Consult with the appropriate authorities having jurisdiction to ensure compliance with all national and local codes regarding recirculating filtered air.

Equipment location must conform to all codes and standards, should be suitable for the type of dust being handled and should ensure easy access for service and utility connections. Site selection must account for wind, seismic zone and other load conditions.

The equipment must be anchored once in final position. Anchors must comply with local code requirements. Anchors, foundation or support framing must be capable of supporting dead, live, wind, seismic, and other applicable loads. Consult a qualified engineer for final selection of foundation or support framing.

Note: Ensure the inlet has at least five diameters of straight duct prior to the collector inlet including a transition to the full inlet dimensions. Inlet transition should have a taper with a maximum of a 90-degree included angle.

Follow industry practice relative to clean air velocity into a fan.

## Provisional Anchor Bolt Recommendations

The quantity of anchor bolts should match the number of holes provided in the base plates of the collector. Anchor diameter is typically 1/8-inch less than the baseplate hole diameter. Anchors should project a minimum of 1 3/4 -inch and account for nut, washer, baseplate, and shims/grout.

## Delivery and Inspection

Upon arrival inspect equipment and report any damage to delivery carrier. File any damage claims with the delivery carrier. Request a written inspection report from the Claims Inspector to substantiate all damage claims.

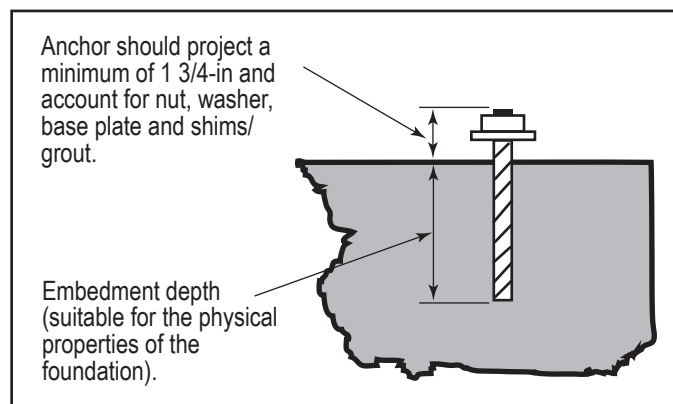

Typical Foundation Anchor

Compare the equipment received with the description of product ordered. Report any incomplete shipments to the delivery carrier and your Donaldson Torit representative.

## Unloading and Positioning



Equipment should be lifted only by qualified crane or fork truck operators.

Failure to lift the equipment correctly can result in severe personal injury and/or property damage.

1. Remove any crates or shipping straps.
2. Lift the packaged collector from transport container.
3. Inspect for any damage and/or missing parts and report to freight carrier.
4. Check for any hardware which may have become loose during shipment and tighten as necessary.

## Lifting Information



Failure to lift the equipment or sub-assemblies correctly can result in severe personal injury and/or property damage. Only qualified crane or forklift operators should be allowed to lift equipment.

1. Use all lifting points provided.
2. Use clevis connectors, not hooks, on lifting slings.
3. Use spreader bars to prevent damage to equipment.
4. Check the Specification Control drawing for weight and dimensions of the collector and components to ensure adequate crane capacity.
5. Lift collector and accessories separately and assemble after collector is in place.
6. Use drift pins to align holes in section flanges during assembly.

## Typical Lifting Guidance

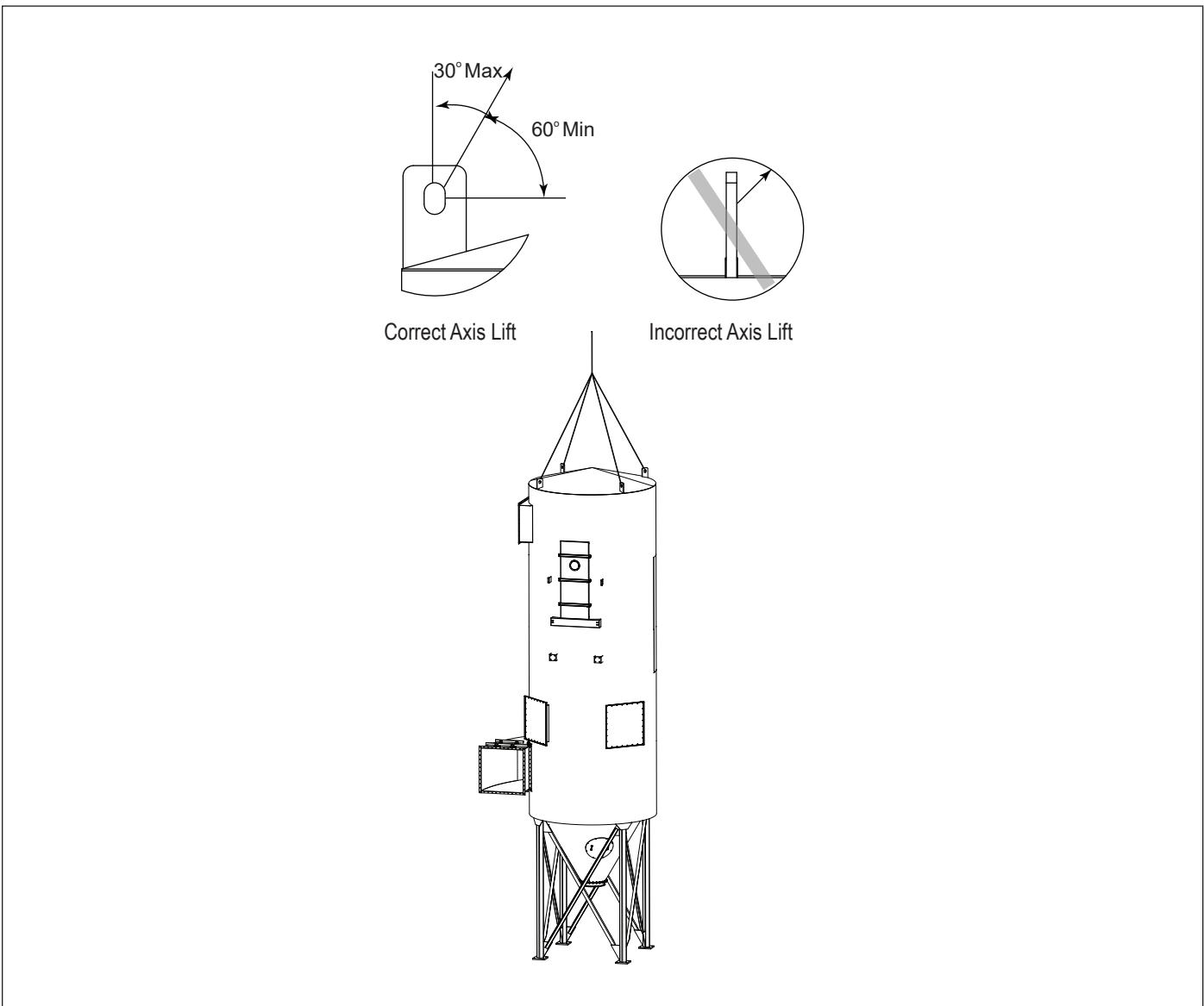

## Support Installation



Anchors must comply with local code requirements and be capable of supporting dead, live, wind, seismic and other applicable loads.

Anchor sizes shown are provisional, as final anchor sizing will depend on jobsite load conditions, equipment location, foundation/framing design variables and local codes.

Consult a qualified engineer for final selection of suitable anchors.

Temporary support is required until all legs and cross-bracing are in place.

Reference Typical Foundation Anchor drawing shipped with the collector prior to starting assembly.

Prepare the foundation or support framing in the selected location. Locate and install anchors.

## Inlet Scroll Installation

1. After the collector housing is upright and secure, remove the temporary vertical supports from the inlet scroll opening on the collector.
2. Place 1/4-in diameter, rope-type sealant toward the inside and outside edge of the bolt pattern in a figure 8 pattern such that sealant will be on inside and outside edge of all flange bolt holes on the inlet-section scroll mounting flanges.
3. Lift inlet scroll into position and secure with the hardware provided.

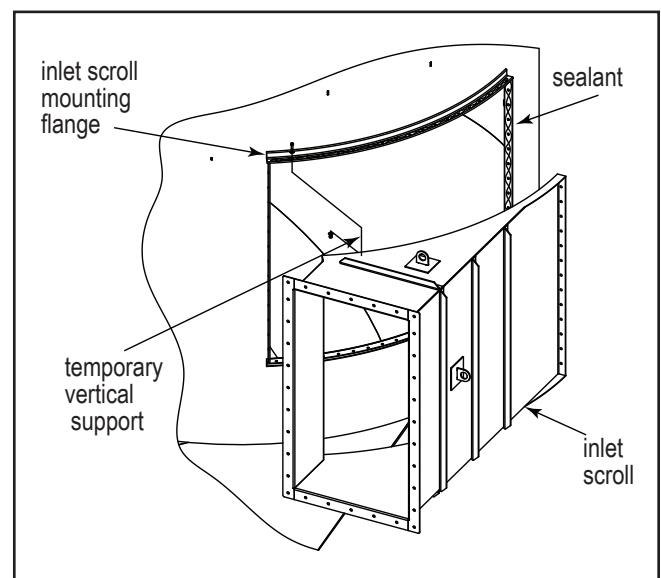

Inlet Scroll Installation

## Platform and Ladder Installation



To avoid possible severe injury or equipment damage do NOT use hand rails or ladders as a lifting point.

Locate ladders to minimize risk of injury from site specific hazards including explosion relief panels.

### NOTICE

Install the railing and ladder only after the filter housing and hopper assemblies are securely fastened to avoid damaging the platform or ladder.

### Platform

1. Depending on the collector model and size, the ladder/platform pack may include one or more platforms.
2. For a list and schematic of components, refer to the ladder and platform (if applicable) assembly drawings provided with the collector.
3. Assemble the platform pack to the collector first.
4. Continue assembling the additional ladder and platform components from top to bottom paying close attention to the assembly drawings.
5. Make sure that all platform and ladder support brackets are installed and the bottom ladder is secured to the foundation with the appropriate brackets and anchors.

### Ladder

1. Assemble the ladder on the ground following the assembly drawing provided with the ladder. Tighten all hardware securely.
2. Attach the crane's lifting slings to the top four ladder rungs.
3. Lift the assembled ladder into position, align holes and secure ladder to the collector using the hardware provided.
4. Position lateral ladder support bracket(s) following the assembly drawing provided with the ladder.
5. Secure bottom of ladder to the ground using anchor bolts.
6. Tighten all hardware.
7. Remove crane.
8. Ladder safety system/personal fall arrest system to be provided by process owner or by others where required.

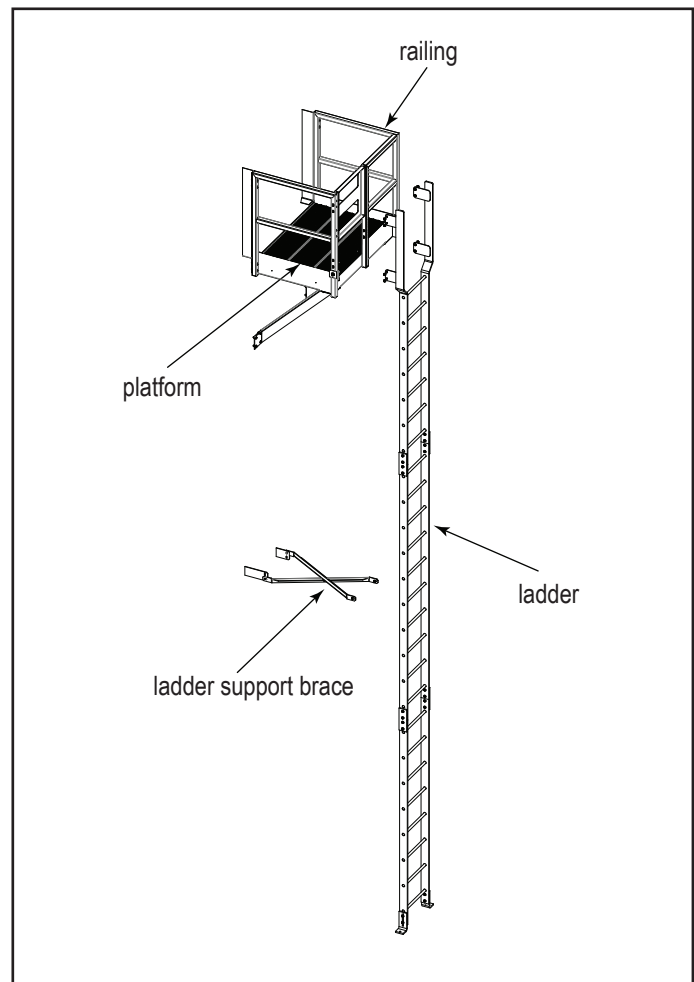

Ladder Installation

## Cleaning System

The cleaning system for the LP has been installed at the plant. Remove bracing securing the cleaning arm to the tube sheet and any bracing keeping the cleaning fan from moving. Make sure that cleaning arm can move while under power.

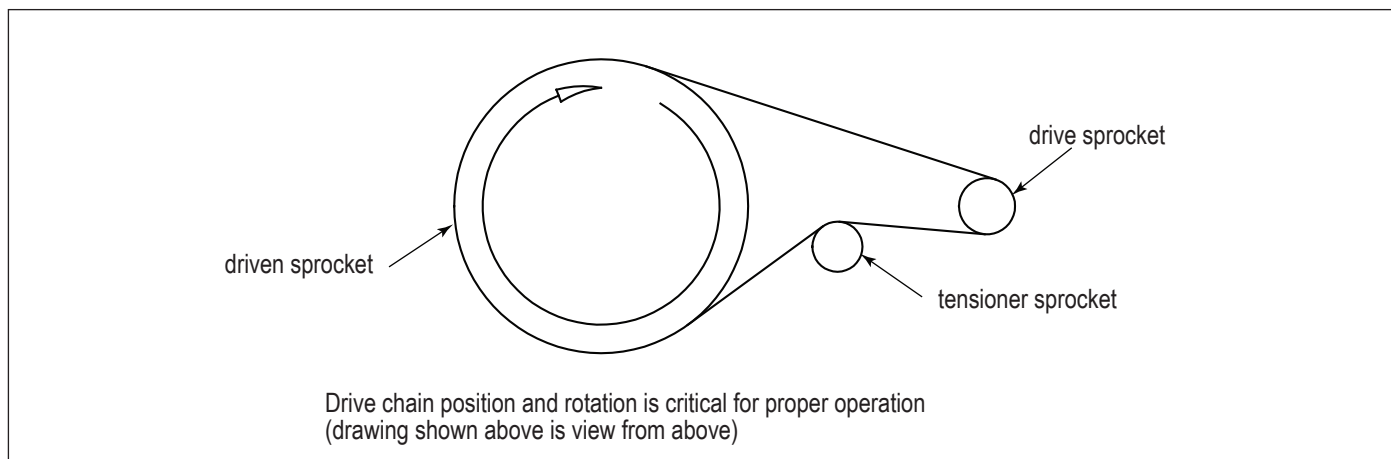
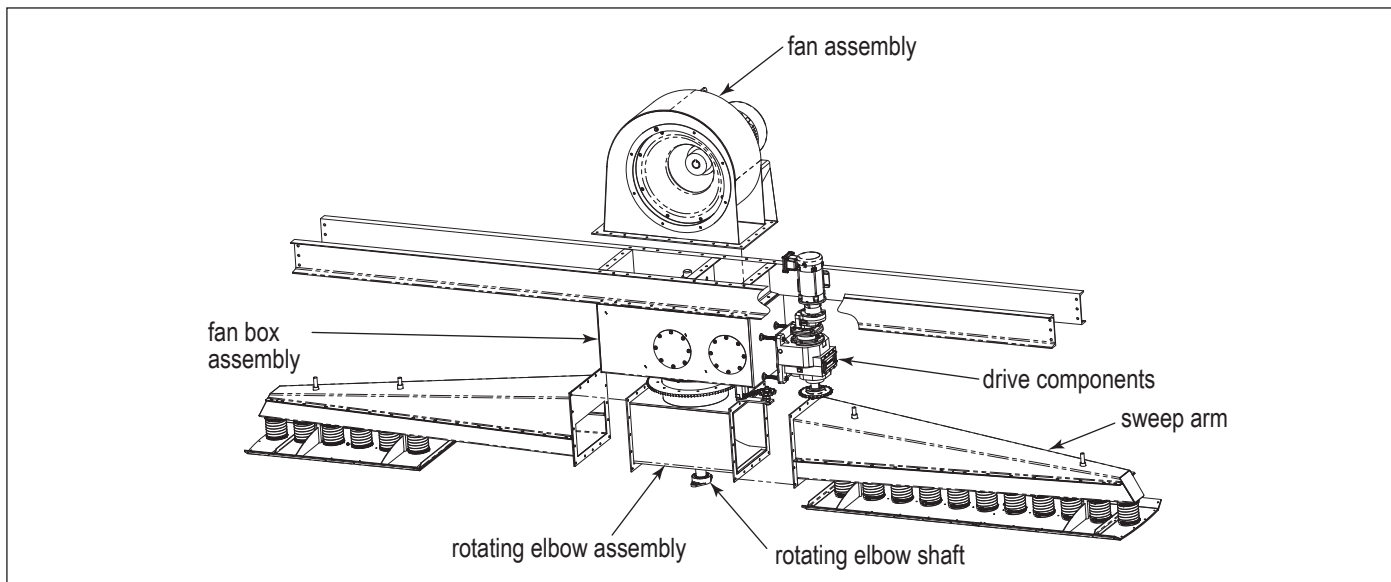

## Filter Bag and Cage Installation

1. Open filter access door into the clean air side.
2. From the clean-air plenum, carefully insert the snap-in filter bag through the tube sheet with the closed end oriented downward.
3. Snap the bag in place with the tube sheet between the upper and lower rings on the filter bag collar.
4. Lower the filter cage into the bag. If the bag section is resting on the ground, the cages will not drop (seat) completely at this time. When the dirty air plenum is lifted into place, the cages will drop to the correct position (fully seat).
5. Repeat steps 3-4 for all remaining filter bags and cages.

Note: The cleaning arm will need to be manually rotated to access some bags.

6. Once all bags are installed, ensure the cleaning arms rotate smoothly.
7. Close the filter access door.

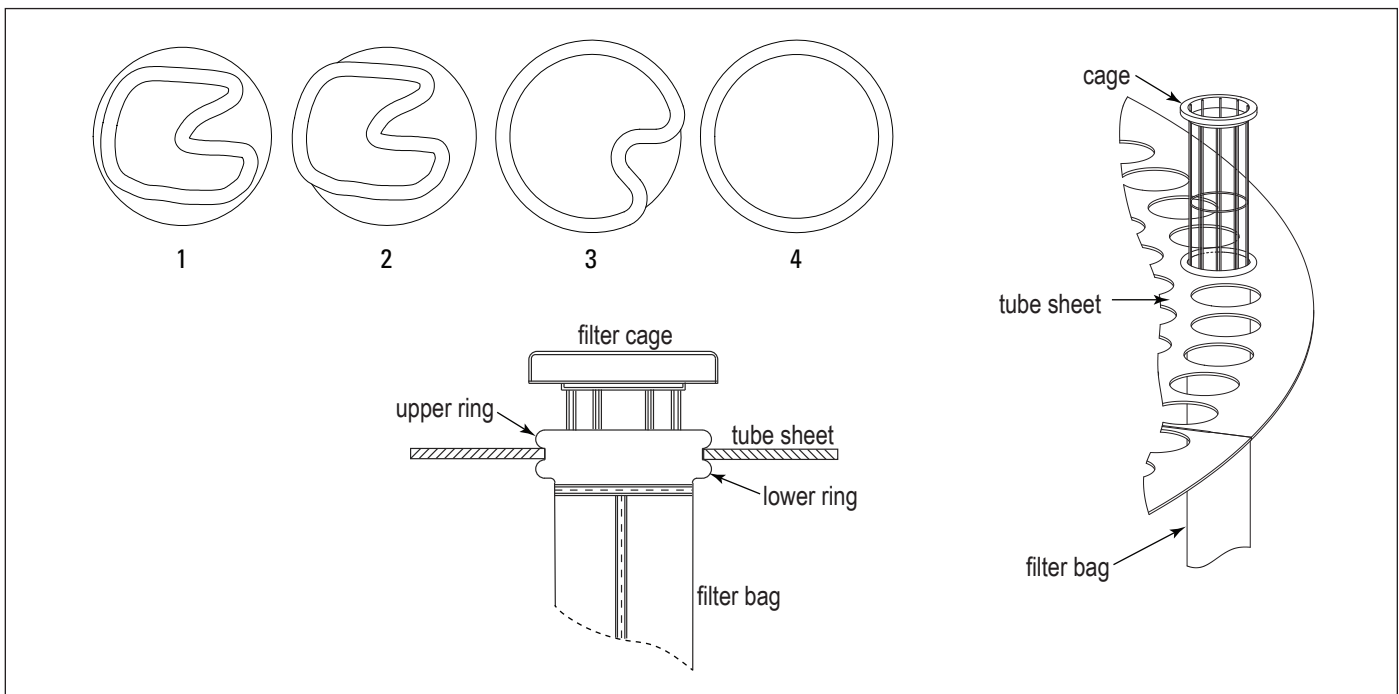

Filter Bag and Cage Installation

## Electrical Wiring



Electrical installation, service, or maintenance work must be performed by a qualified electrician and comply with all applicable national and local codes.

This equipment may start or stop unexpectedly from a remote location.

Turn power off and lock out all power before performing service or maintenance work.

The appropriate wiring schematic and electrical rating must be used. See collector's rating plate for required voltage.

Do not install in classified hazardous atmospheres without an enclosure rated for the application.

## Cleaning Controls and Sensors

### Magnehelic® Gauge

The Magnehelic is a differential pressure gauge used to measure the pressure difference between the clean-air and dirty-air plenums and provides a visual display of filter change requirements. The high-pressure tap is located in the dirty-air plenum and the low-pressure tap is located in the clean-air plenum.

1. Choose a convenient, accessible location on or near the collector for mounting that provides the best visual advantage.
2. Plug the pressure ports on the back of the gauge using two, 1/8-in NPT pipe plugs supplied. Install two, 1/8-in NPT male adapters supplied with the gauge into the high- and low-pressure ports on the side of the gauges.
3. Attach the mounting bracket using three, #6-32 x 1/4-in screws supplied.
4. Mount the gauge and bracket assembly to the supporting structure using two, self-drilling screws.
5. Thirty-five feet of plastic tubing is supplied and must be cut in two sections. Connect one section of tubing from the gauge's high-pressure port to the pressure fitting located in the dirty-air plenum. Connect remaining tubing from the gauge's low-pressure port to the fitting in the clean-air plenum. Additional tubing can be ordered from your representative.
6. Zero and maintain the gauge as directed in the manufacturer's Operating and Maintenance Instructions provided.

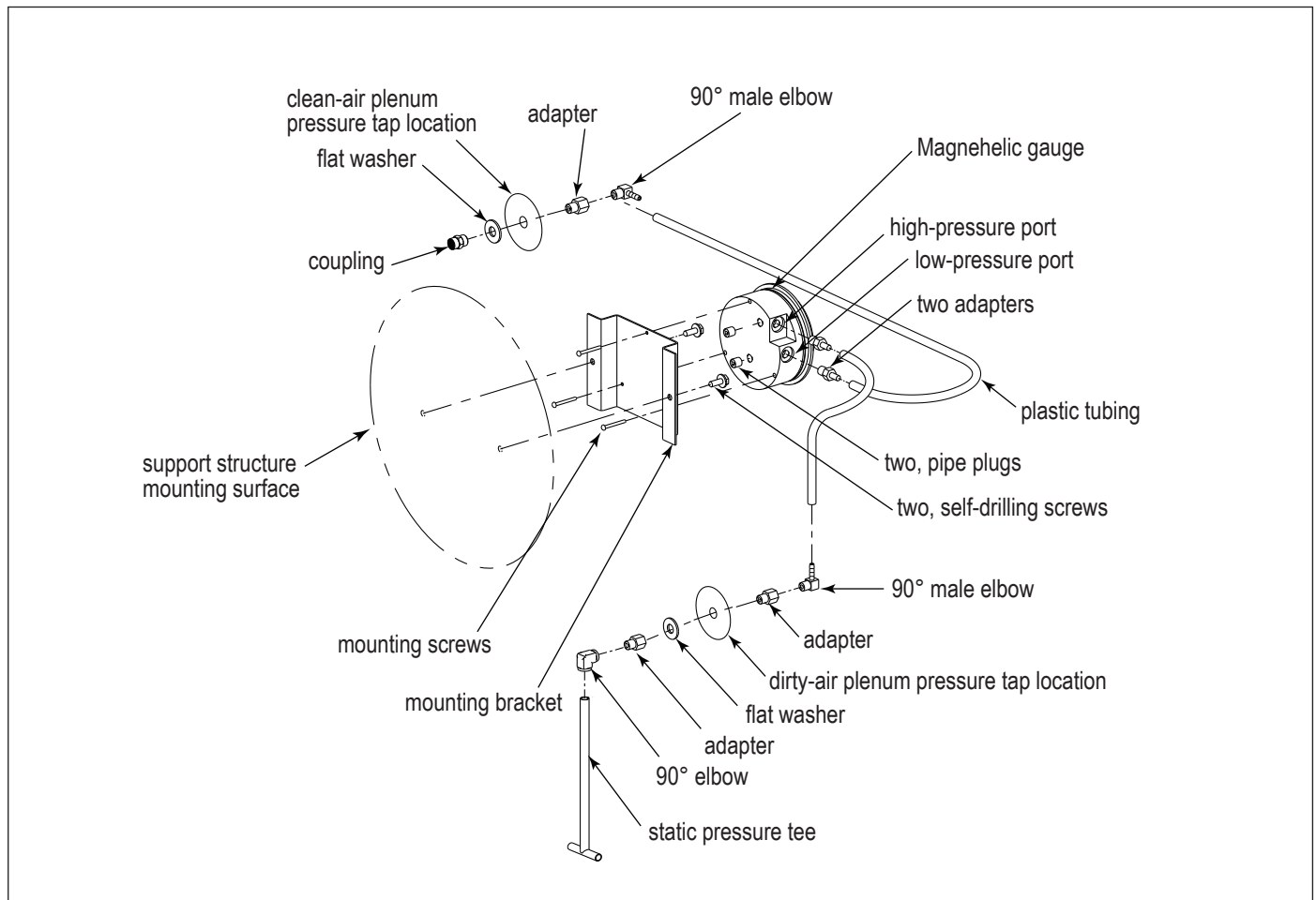

Magnehelic Gauge Installation

## Hopper Discharge Accessories

### Rotary Airlock



Rotating blades can cause serious injury.

Turn power off and lock out all power before performing service or maintenance work.

Keep hands, feet and loose clothing away from both inlet and outlet openings to avoid injury or damage when airlock is operating.

#### **NOTICE**

Optional discharge devices may require independent support. Discharge devices over 800 lbs. must be independently supported.

Hopper discharge devices must be sized to handle anticipated dust volumes. Dust may discharge infrequently as cleaning dislodges accumulated dust at above average levels and the airlocks should be sized to accommodate these conditions.

Rotary airlocks are used to maintain a seal on the hopper outlet while material is discharged from the hopper. A transition allows an airlock to be connected to the hopper discharge when there is a size difference between the hopper outlet and the airlock inlet.

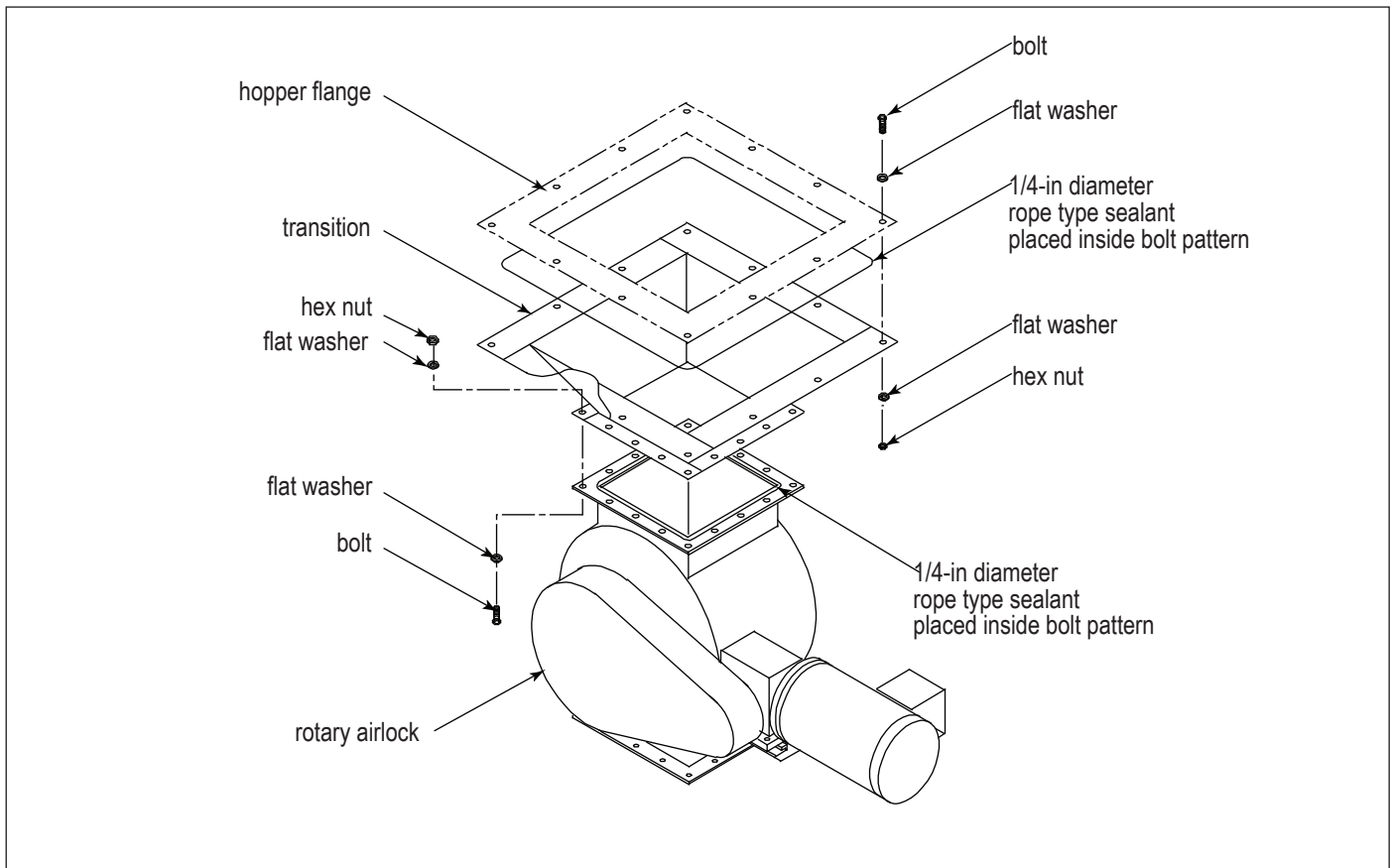

Rotary Airlock



## Options and Accessories

### Explosion Relief Panels



Personal injury, death, and/or property damage can result from material discharge during venting.

The material of an explosion must be safely directed outdoors away from areas occupied by personnel to reduce risk of personal injury and/or property damage.

The risk of personal injury and/or property damage can be minimized or avoided by locating vented equipment outside buildings and away from normally occupied areas.

Explosion vents should be inspected regularly to confirm physical and operational condition. Replace any damaged parts immediately.

Standard explosion vents are intended for outdoor installations only.

Unless otherwise noted, the explosion venting calculations are based on formulas from NFPA-68 for outdoor applications only, with no duct or obstructions on the explosion vent panel.

Contact Donaldson Torit for assistance in calculating specific venting requirements for equipment.

NFPA 68 can provide guidance on both the frequency of and appropriate details for inspections.

### Sprinkler Coupling

**NOTICE**

Sprinkler couplings are provided for the convenience of fire control system installers. The fire control system installer shall make their own decisions on the appropriate location of fire control system components.

### Water Overflow Valve

1. Remove the hopper access cover and set aside.
2. Align holes in water overflow valve access cover with holes in hopper. Secure using the flat washers and hex nuts removed in Step 1.
3. Tighten all hardware securely.

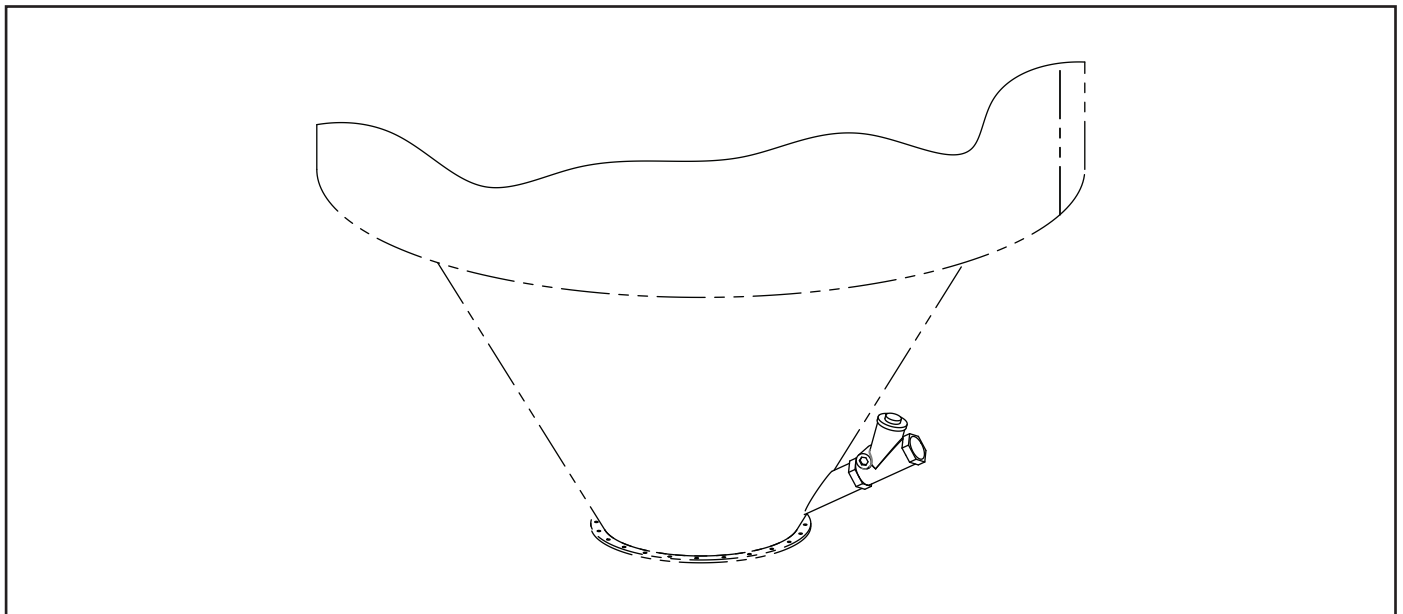

Water Overflow Valve Installation

## Start-up / Commissioning Collector

Instruct all personnel on safe use and maintenance procedures.



Electrical installation, service, or maintenance work must be performed by a qualified electrician and comply with all applicable national and local codes. This equipment may start or stop unexpectedly from a remote location.

Turn power off and lock out all power before performing service or maintenance work.

Check that the collector is clear and free of all debris before starting.

Do not install in classified hazardous atmospheres without an enclosure rated for the application.

Once the LP has been placed, anchored, connected to electrical power and ducts attached to the appropriate equipment, the collector is ready for initial start and commissioning.

1. Ensure there are no obstructions or foreign objects (tools, lifting equipment, etc.) near the reverse air fan.
2. Confirm the cleaning system fan rotation is correct.
  - a. "Bump" the fan to initiate rotation.
  - b. As the fan is winding down (unpowered), compare fan rotation to the rotation label (located on fan housing) direction.
3. If the fan rotation is reversed, correct the rotation.
  - a. Turn off the collector and Lock-Out all energy sources.
  - b. Within the junction box, swap the connection location of two power leads on the terminal block, making certain not to swap a power lead and the ground wire.



Do not interchange a power lead with a ground wire or severe personal injury and/or property damage may result.

4. Confirm the cleaning arm rotation is correct.
  - a. Activate the cleaning arm drive motor to initiate rotation.
  - b. Observe arm rotation relative to the rotation label located on top of the sweep arm.
5. If the arm rotation is reversed, correct the rotation.
  - a. Turn off the collector and Lock-Out all energy sources.
  - b. Within the junction box, swap the connection location of two power leads on the terminal block, making certain not to swap a power lead and the ground wire.



Do not interchange a power lead with a ground wire or severe personal injury and/or property damage may result.

6. Ensure the Magnehelic gauge is properly installed and functioning. Refer to the included print for additional instruction.
7. Ensure all collector access panels and doors are sealed and secure.
8. Check that the hopper discharge gate is open and the storage container is properly sealed, if equipped.
9. Check and remove all loose items in or near the inlet and outlet of the collector.
10. Check that all remote controls are properly wired and all service switches are in the OFF position.
11. Ensure all bags and cages are installed and secure.
12. Check that all optional accessories are installed properly and secured.

## Decommissioning Collector

Once the collector has reached the end of operational life it will need to be decommissioned.



During decommissioning, there is potential for exposure to the dust in the collector. Most dusts present safety and health hazards that require precautions. Wear eye, respiratory, head, and other protection equipment suitable for the type of dust when performing any decommissioning activities.

LOCK-OUT all energy sources prior to performing any decommissioning activities on the equipment.

Electrical service must be performed by a qualified electrician.

Disconnection of ducts must be performed by a qualified tinsmith or contractor.

1. Follow the typical shut-down sequence steps located in the operation section to remove as much contaminant from collector as possible.
2. Lock-Out all energy sources.
3. Remove all filters from the collector and dispose of in a suitable fashion for the dust in the collector. (See Filter Replacement for removal instructions).
4. Disconnect electrical power from the collector and remove any associated conduit or hardware from the exterior of the collector.
5. Disconnect all ducts from the collector.
6. Proceed to disassemble collector by removing sub-assemblies in the reverse order of the steps given in Appendix A.  
Note: The clean air plenum, dirty air plenum, tube sheet, H-frame and cleaning assembly may be removed in separate steps instead of as one unit.
7. Once all cross-bracing has been taken down, remove anchor bolts and lower leg pack columns.
8. Secure all collector components to a suitable transport carrier and transport to a disposal site suitable for the dust in the collector.

**Product Information**

(Process Owner to complete and retain for your records)

Model Number _____	Serial Number _____
Ship Date _____	Installation Date _____
Filter Type _____	
Collected Dust _____	
Dust Properties: Kst _____	Pmax _____ MIE _____ MEC _____
Accessories _____	
Other _____	
_____	





## Donaldson Industrial Air Filtration Warranty

Donaldson warrants to the original purchaser only that the Goods will be free from defects in material and manufacture for the applicable time periods stated below: (1) Major structural components for a period of ten (10) years from the date of shipment; (2) Non-Structural, Donaldson-built components and accessories including Donaldson Airlocks, TBI Fans, TRB Fans, Fume Collector products, Donaldson built electrical control components, and Donaldson-built Afterfilter housings for a period of twelve (12) months from date of shipment; and (3) Donaldson-built filter elements for a period of eighteen (18) months from date of shipment.

Buyer is solely responsible for determining if goods fit Buyer's particular purpose and are suitable for Buyer's process and application. Seller's statements, engineering and technical information, and recommendations are provided for the Buyer's convenience and the accuracy or completeness thereof is not warranted. If, after Seller receives written notice, within the warranty period, that any goods allegedly do not meet Seller's warranty, and Seller, in its sole discretion, determines that such claim is valid, Seller's sole obligation and Buyer's exclusive remedy for breach of the foregoing warranty or any Seller published warranty, will be, at Seller's option, either: (i) repair or replacement of such goods or (ii) credit or refund to Buyer for the purchase price from Seller. In the case of repair or replacement, Seller will be responsible for the cost of shipping the parts but not for labor to remove, repair, replace or reinstall the allegedly defective goods. Refurbished goods may be used to repair or replace the goods and the warranty on such repaired or replaced goods shall be the balance of the warranty remaining on the goods which were repaired or replaced. Any repair or rework made by anyone other than Seller is not permitted without prior written authorization by Seller, and voids the warranty set forth herein. Seller warrants to Buyer that it will perform services in accordance with the Sales Documents using personnel of required skill, experience and qualifications and in a professional and workmanlike manner in accordance with generally recognized industry standards for similar services. With respect to any services subject to a claim under the warranty set forth above, Seller shall, in its sole discretion, (i) repair or re-perform the applicable services or (ii) credit or refund the price of such services at the pro rata contract rate and such shall be Seller's sole obligation and the exclusive remedy for breach of the foregoing warranty on services. Products manufactured by a third party ("Third Party Product") may constitute, contain, be contained in, incorporated into, attached to or packaged together with, the goods. Buyer agrees that: (a) Third Party Products are excluded from Seller's warranty in this Section 7 and carry only the warranty extended by the original manufacturer, and (b) Seller's liability in all cases is limited to goods of Seller's design and manufacture only. EXCEPT FOR SELLER'S WARRANTY OF TITLE TO THE GOODS, SELLER EXPRESSLY DISCLAIMS AND EXCLUDES ALL OTHER WARRANTIES WHATSOEVER, WHETHER, EXPRESSED OR IMPLIED, ORAL, STATUTORY, OR OTHERWISE, INCLUDING BUT NOT LIMITED TO MERCHANTABILITY, FITNESS FOR A PARTICULAR PURPOSE, NON-INFRINGEMENT OF THIRD PARTY INTELLECTUAL PROPERTY AND ANY WARRANTIES ARISING FROM TECHNICAL ADVICE OR RECOMMENDATIONS, COURSE OF DEALING OR OF PERFORMANCE, CUSTOM OR USAGE OF TRADE. Seller's obligations do not cover normal wear and tear or deterioration, defects in or damage to any goods resulting from improper installation, accident or any utilization, maintenance, repair or modification of the goods, or any use that is inconsistent with Seller's instructions as to the storage, installation, commissioning or use of the goods or the designed capabilities of the goods or that, in its sole judgment, the performance or reliability thereof is adversely affected thereby, or which is subjected to abuse, mishandling, misuse or neglect or any damage caused by connections, interfacing or use in unforeseen or unintended environments or any other cause not the sole fault of Seller, and shall be at Buyer's expense. Seller's warranty is contingent upon the accuracy of all information provided by Buyer. Any changes to or inaccuracies in any information or data provided by Buyer voids this warranty. Seller does not warrant that the operation of the goods will be uninterrupted or error-free, that the functions of the goods will meet Buyer's or its customer's requirements unless specifically agreed to, or that the goods will operate in combination with other products selected by Buyer or Buyer's customer for its use.

The terms of this warranty may only be modified by a special warranty document signed by a Director, General Manager or Vice President of Donaldson. To ensure proper operational performance of your equipment, use only genuine Donaldson replacement parts.

**This Product is provided subject to and conditioned upon Donaldson's Terms of Sale ("Terms"), a current copy of which is located at [termsofsale.donaldson.com](http://termsofsale.donaldson.com). These Terms are incorporated herein by reference. By purchasing or using this Product, the user accepts these Terms. The Terms are available on our website or by calling our customer service line at 1-800-365-1331.**

Significantly improve the performance of your collector with genuine Donaldson Torit replacement filters and parts.

---

**Important Notice:** Many factors beyond the control of Donaldson can affect the use and performance of Donaldson products in a particular application, including the conditions under which the product is used. Since these factors are uniquely within the user's knowledge and control, it is essential the user evaluate the products to determine whether the product is fit for the particular purpose and suitable for the user's application. All products, product specifications, availability and data are subject to change without notice, and may vary by region or country.

